

Inflatocookbook



 ant farm

WORLD'S *first*

INFLATABLE

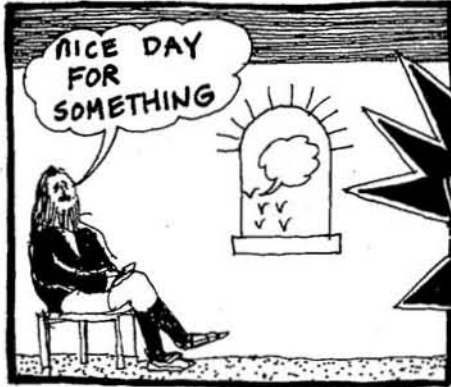

.... HE WOULD OFTEN DRY AND CLEAN THE GUTS OF A BULLOCK

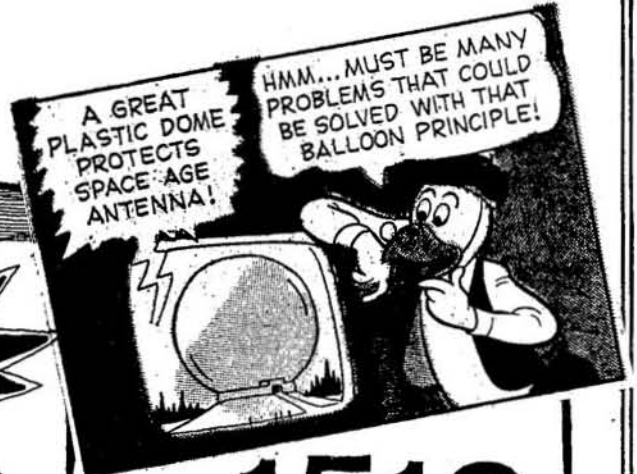
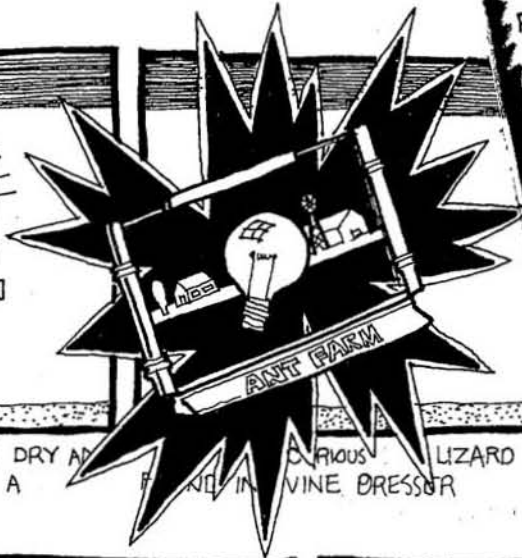

1512

MAKE THEM SO SMALL THAT THEY MIGHT BE HELD IN THE PALM OF THE HAND



IN ANOTHER ROOM HE KEPT A SMITH BELLOWS

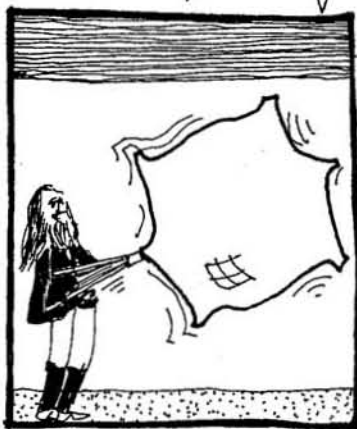

WITH THESE BLOW GUTS



UNTIL IT FILLED THE ROOM FORCING ANYONE THERE TO TAKE REFUGE IN A CORNER.....



thanks to Leonardo da Vinci

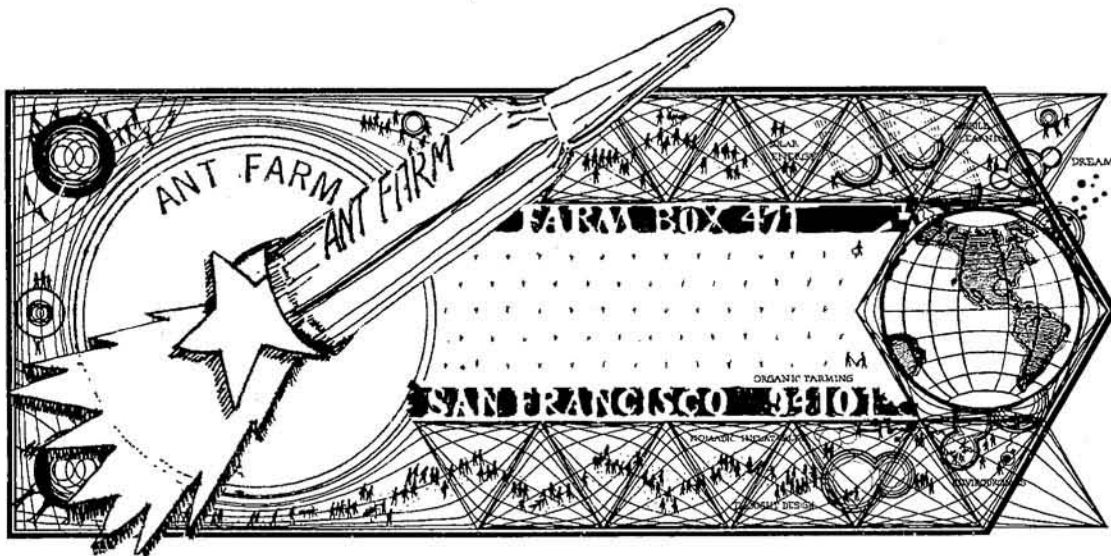

The INFLATOCOOKBOOK was first published in Jan. 1971 by Ant Farm. It was our attempt to gather information and skills learned in process and present it in an easily accessible format. That INFLATOCOOKBOOK came loose leaf in a vinyl binder that we fabricated in our warehouse in Sausalito. The first printing was 2000 copies.

74
1099
I42
1942

The experiences that qualified us as 'Inflato-experts' occurred over an 18 month period in which we designed, built, and erected inflatables for a variety of clients and situations. Charley Tilford showed Ant Farm how to make fast, cheap inflatables out of polyethylene and tape and support them with used fans from Goodwill. That was in the fall of 1969. The first one built was the largest, a 100'x100' white pillow that was built for the ill fated Wild West Festival in San Francisco, then after being turned down for Stewart Brand's Liferaft Earth Event, finally had its day at Altamont. There followed a year in which we built numerous demo-inflatables at schools, conferences, festivals and gatherings around the state of California and beyond.

ANT FARM at that time was: Andy Shapiro, Kelly Gloger, Fred Unterseher, Hudson Marquez, Chip Lord, Doug Hurr, Michael Wright, Curtis Schreier, Joe Hall, and Doug Michels.

The INFLATOCOOKBOOK was written, designed, and put together by: Chip Lord, Curtis Schreier, Andy Shapiro, Hudson Marquez, Doug Hurr, Doug Michels with help from: Sylvia Dreyfus, Charley Tilford, and Sotiti Kitrilakis.

This SECOND PRINTING (July 1973) takes on a new form for ease of printing and distribution. It gets a new cover and binding, and some material has been omitted for update. Still its a good buy at the original price of 3.00\$, only at one place; thats Box 471 San Francisco Calif 94101

PNEUMADS MATERIALS EVENTS GEOMETRY FUNDAMENTALS FANTASY ANCHORING AIR SUPPLY

ENTRANCE

OIL MASSAGE

THE WORLD'S LARGEST SNAKE

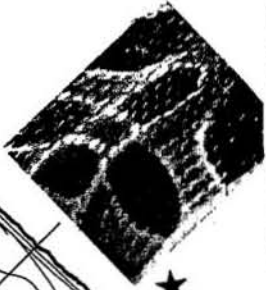

★

★ 3

g

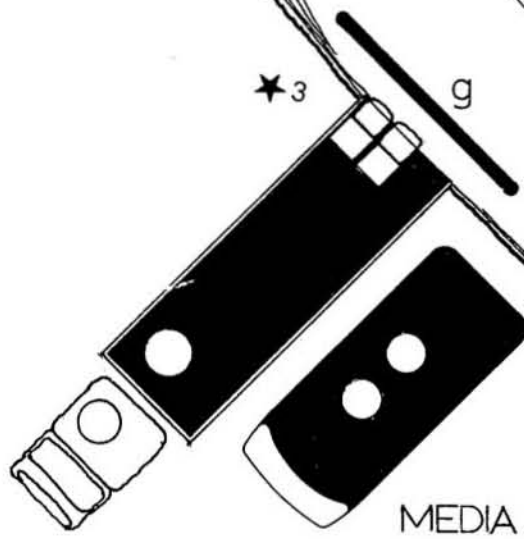

MEDIA VAN

★ ENTRANCE DETAIL



50

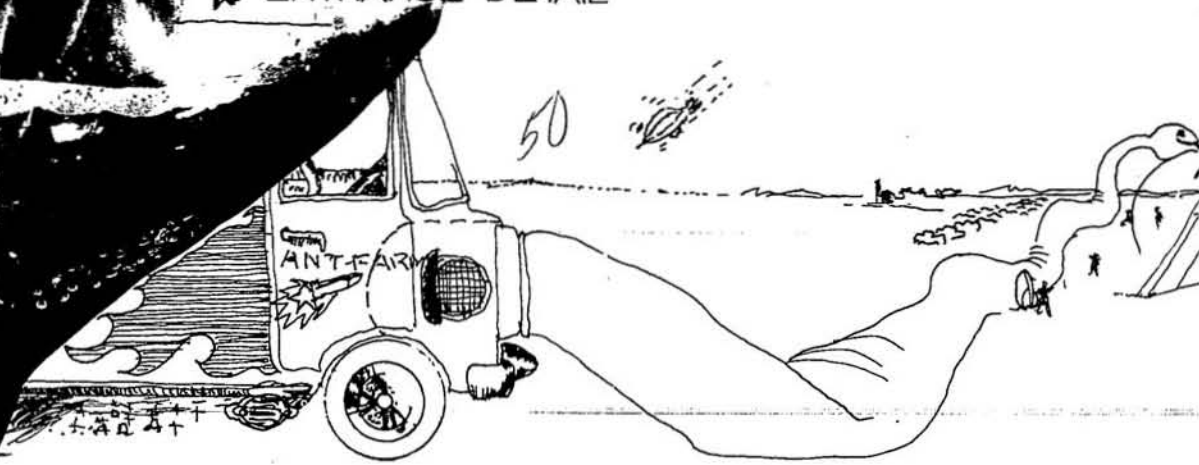

FANTASY

The World's Largest Snake Alphabet
 Electroasis-instant media &
 The Universal Mass Consumption Grid
 Erection American shopping centers
 Livin' & jivin' - a & b
 or university automatons/sto. - c&e
 Ultrasonic media blasts from d
 Blow it up - f
 The World's Largest Snake eats
 videoscreens - g & a 5 man crew
 explores limits, blows up buildings,
 destroy Fat City, build real (C)ity
 Solar energy, dreams, enviroyesterday
 mobiletomorrow AND
 We give 10X energy credits with fillup.



SECTION at CADDY

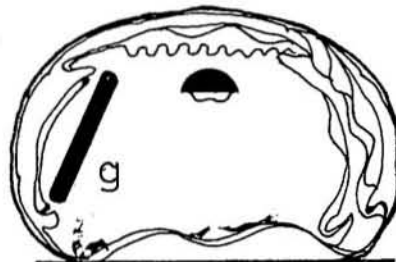

SECTION at CLOUD

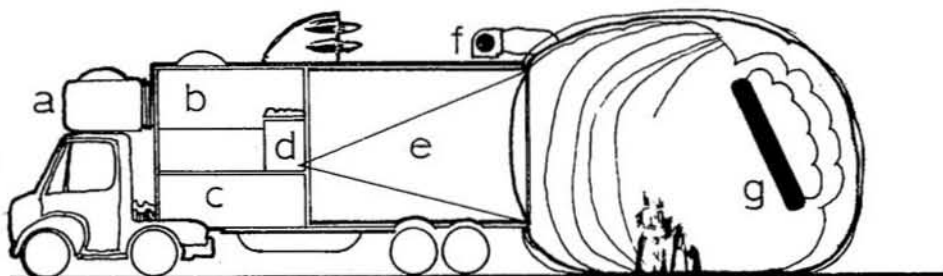

WORLD'S LARGEST, SNAKE TRUCK SECTION

SNAKE RATTLE & ROLL ROOM

57 CADDY

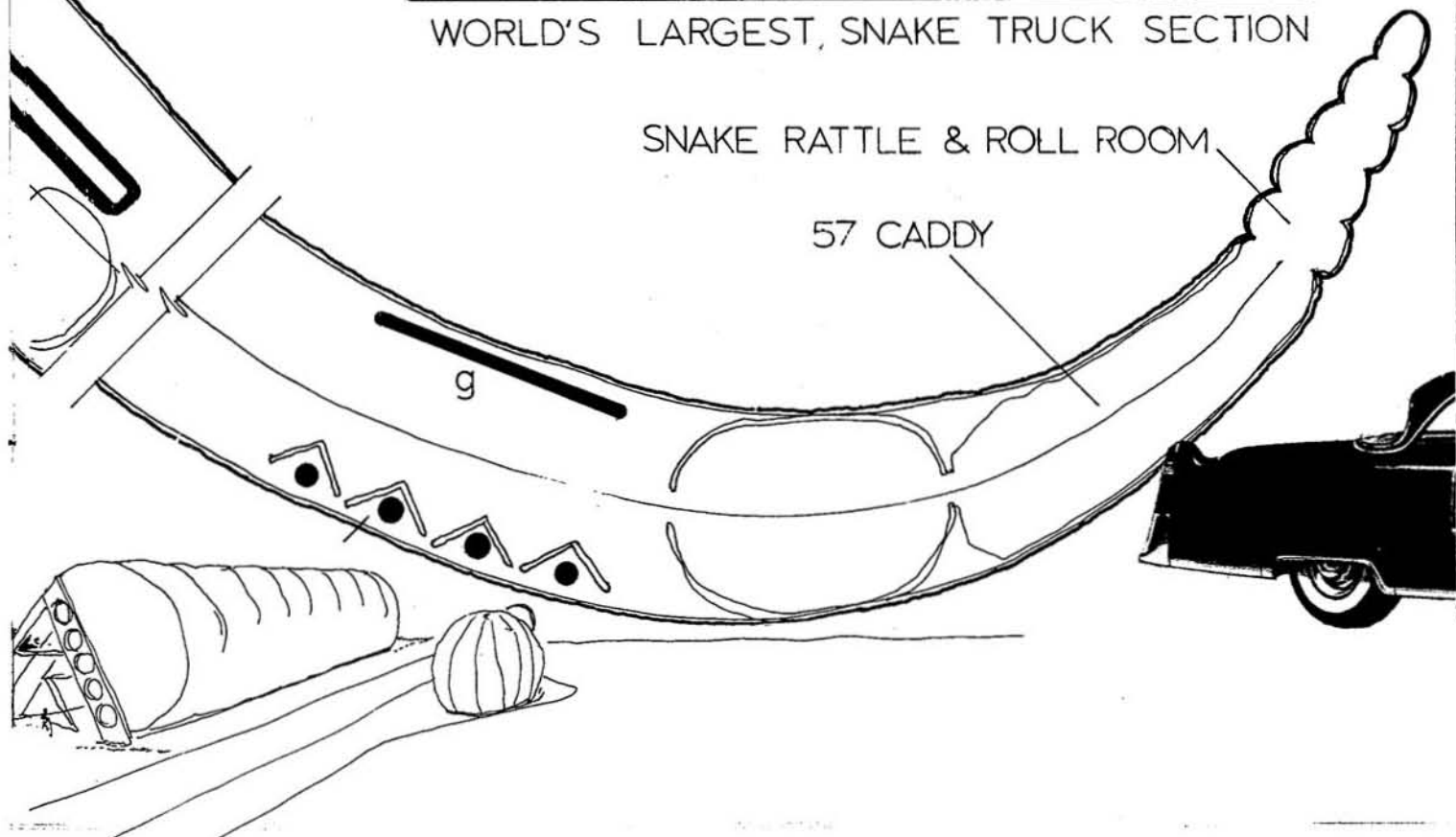

EVENTS ANT FARM FUNKI-TECH FANTASY

the holes. Adjust the size of the neckhole by pinching it closed — the tautness or limpness of the structure if under your control. Tape the neckhole shut and inflate fully. Notice the wrinkles near the shoulder of the bag. With a knife cut a 3" slit ACROSS the wrinkles. Notice what happens, immediately, to the hole. Now try again — deflate the bag and tape the hole with your tape — then turn the blowers on again. This time make a slit ALONG one of the wrinkles. Notice what it does. Try this again at a place where there are no wrinkles. Any difference? Of the two, which way would you cut if you were making a door and you wanted to conserve air?

3. Get some thicker plastic somewhere.

Large orange or red pieces come as covers on flatcar loads of gypsum wallboard. Large black pieces come stapled to the side of a two-part mobile home, as it goes down the highway. Black and clear pieces are used by construction crews to cover things up and to put under concrete slabs. A real find is clear plastic reinforced with nylon mesh used in greenhouses. Make sure that the piece is at least nine feet across; a rectangle nine by some larger dimension to make a structure you can crawl thru. Larger means finer and more fun. (A tube 3 feet across you remember from geometry requires a piece of material 9.42 feet across.) Find some tape — the 2" polythene stuff used in the construction industry is good.

If you are careful and the plastic is clean and flat you can use 3/4" vinyl electrical tape but it is hard going. Masking tape is poor and water gummed tapes won't begin to stick. Mother's hot iron can seal if she doesn't mind it getting gooped up with melted plastic.

Cut off any ragged edges to make a rectangle. Lay two opposite ends together and tape to form a tube. Then tape one closed and tape the other end around a window fan. For a real treat tape to an air conditioner or a heater/blower. Turn on the power and watch it inflate. Cut a slit (remembering what you learned in Experiment 2 about wrinkles) and CRAWL IN.

Write a 40 page thesis about what you are seeing inside and mail it to ANT FARM for your full color BACHELOR BUTTON and degree. CONGRATULATIONS as you are probably all keyed up with a thousand fantasies — inflating from airplanes, car heaters, down-lined, fur lined, wire powered, love-making, flag flying. The next sections of this book are encyclopedic, with enough information to get your fantasies off the ground. All the ant farm experience would be air-shake-reading if you hadn't the strength of your own fantasy.

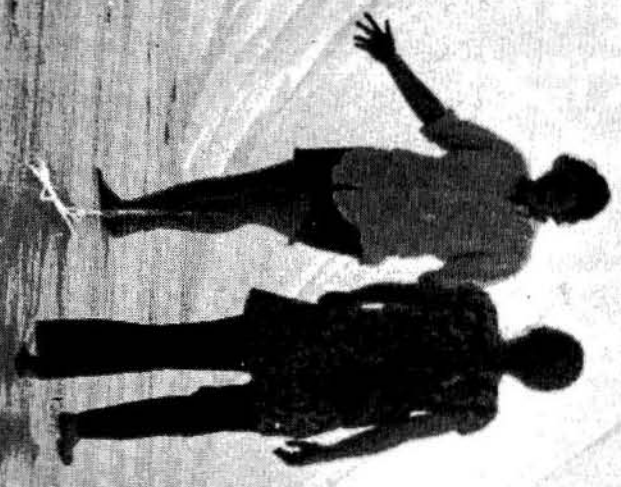

DONALD DUCK

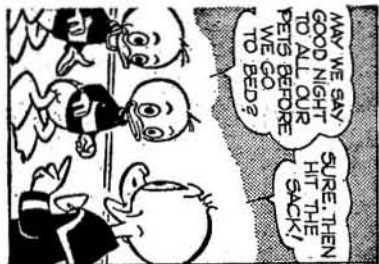

In case you hadn't figured out a reason or excuse, why to build inflatables becomes obvious as soon as you get people inside. The freedom and instability of an environment where the walls are constantly becoming the ceilings and the ceiling the floor and the door is rolling around the ceiling somewhere releases a lot of energy that is usually confined by the XYZ planes of the normal box-room. The new-dimensional space becomes more or less whatever people decide it is — a temple, a farmhouse, a suffocation torture device, a pleasure dome, a conference, party, wedding, meeting, regular Saturday afternoon becomes a festival.

To unfold, inflate and see each other in a black white red purple cloudballoon can conditions right! help to break down people's category walls about each other and their own abilities and can be a hint at the idea that maybe anybody can should must take space-making beautifying into her, his own hands.

A COURSE IN GETTING ACQUAINTED WITH INFLATABLES
CHAPTER 1 OF THE INFLATO-COOKBOOK

1. Take a baggie from Mother's larder. Hold the end open and scoop in some air. Seal the end with tape. Essentially all inflatables work by encapsulating air within a closed membrane. Soon you will begin to notice the bag getting limp. Obviously, air is escaping thru holes and creases in your lousy taping job. Repeat the experiment using a hot knife to seal the open end. By sealing all the way across the opening except for a small orifice, the baggie can be blown up tightly like a rubber balloon and sealed with touch of the hot iron. Notice the wrinkles in the plastic. If you have blown it up tightly, you can imagine a long baggie, with one hundred people sealed inside and realize that the air permanently entrained could not last long, unless you had enough plants in with them. Scotts, maker and taker of green, says that a 50 by 50 plot of lawn turf releases enough oxygen to supply a family of four.
2. Get some cleaner bags, you know, those all-plastic ones with all the dreadful warnings about this is not a toy, and get some scotch tape and lay hands on a blower of some kind, a small fan. Mother's hair dryer is ideal and a vacuum cleaner blower is powerful. Tape the open end of the cleaner bag around the delivery end of whatever blower or around the guard of the fan. Turn on the power. Notice what happens, even though the neck hole of the bag has been left open. For the structure to become inflated, more air must be coming in thru the blower than is flowing out thru

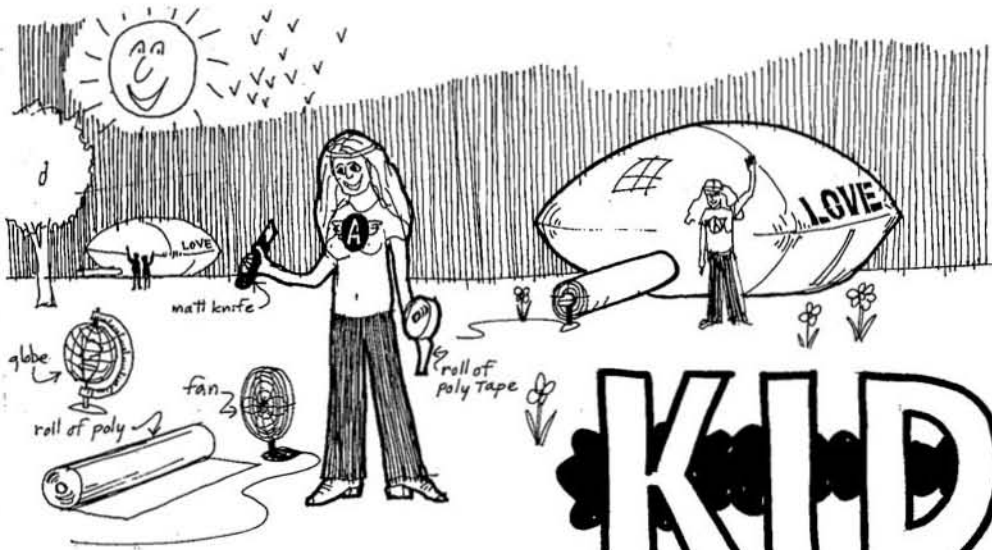

KIDS

make your own bubble
EASY AS 1*2*3

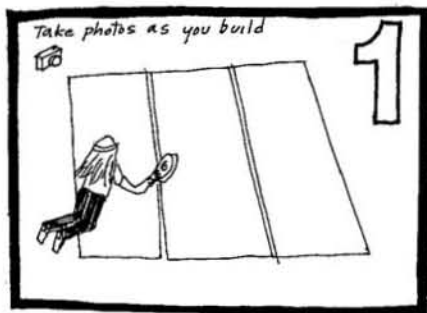

Tape strips of poly together into a large square....

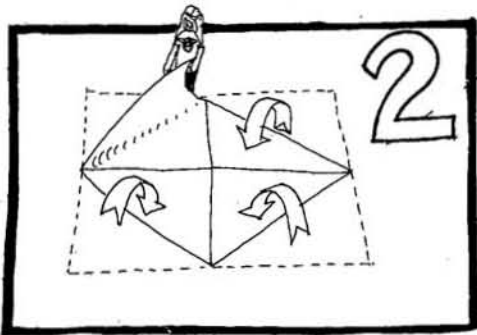

Fold edges over and tape.....

CUT ME OUT

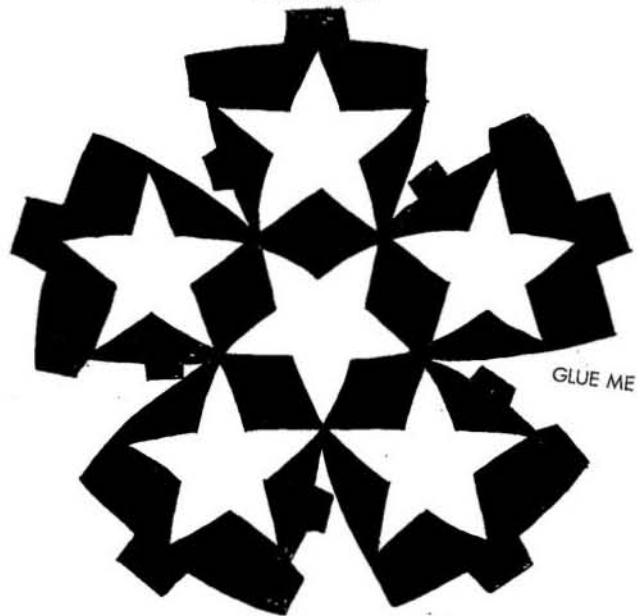

GLUE ME

STICK ME ON FLAG

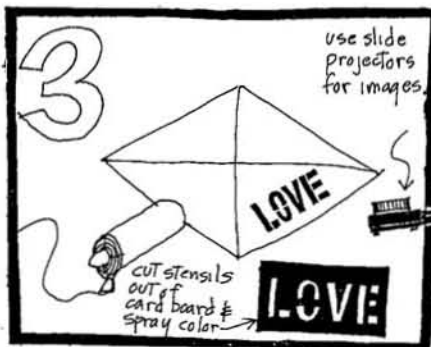

Make tube for fan, inflate & cut entry slit.



Invite friends:



spend the night together.....

KIDS

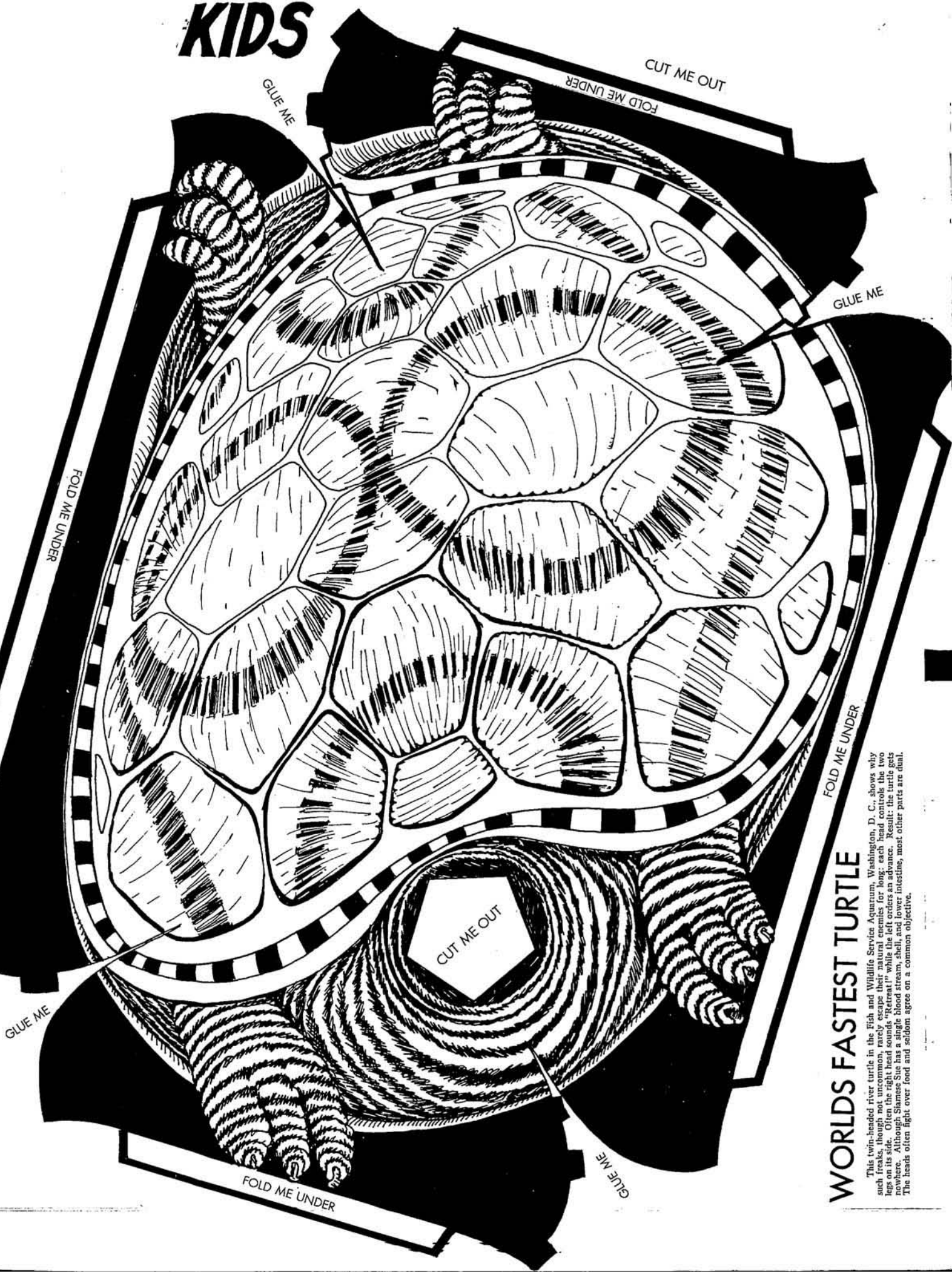

WORLDS FASTEST TURTLE

This twin-headed river turtle in the Fish and Wildlife Service Aquarium, Washington, D. C., shows why such freaks, though not uncommon, rarely escape their natural enemies for long: each head controls the two legs on its side. Oke, the right head sounds "Retreat!" while the left orders an advance. Result: the turtle gets nowhere. Although Shamese has a single blood stream, shell, and lower intestine, most other parts are dual. The heads often fight over food and seldom agree on a common objective.

feet

40

GLUE ME

FOLD ME UNDER

GLUE ME

FOLD ME UNDER

FOLD ME UNDER

CUT ME OUT

CUT ME OUT

FOLD ME UNDER

ALL AMERICAN BAG

GEOMETRY

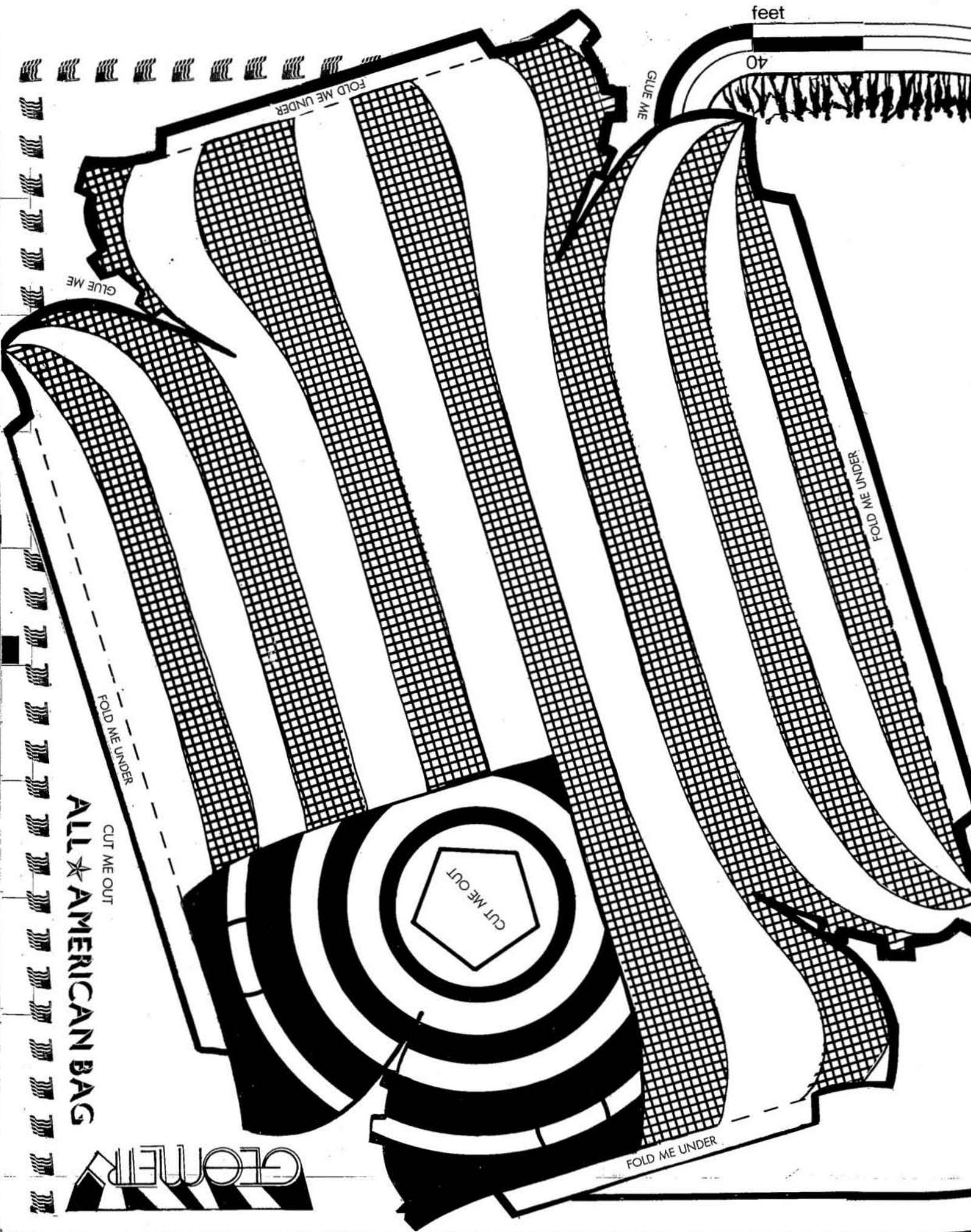

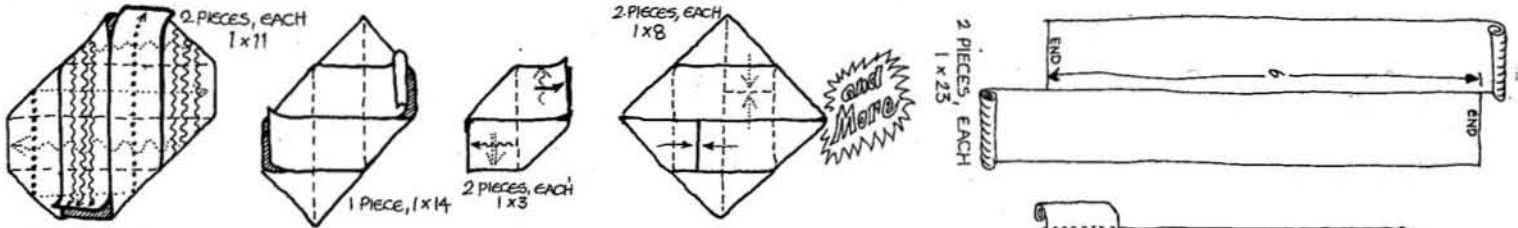

Most plastic available comes in strips or rolls. Here are several methods of making pillow shapes most economically from single, double, etc. continuous strips. Experiment with small ribbons first: to do these at full scale requires lots of layout space and a choreography of teamwork among those unrolling, holding, and taping the plastic.

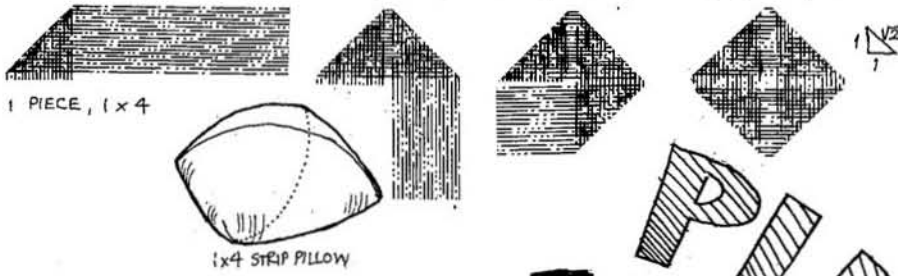

STICK ME ON TURTLE

CUT ME OUT

GLUE ME

TALK FROM

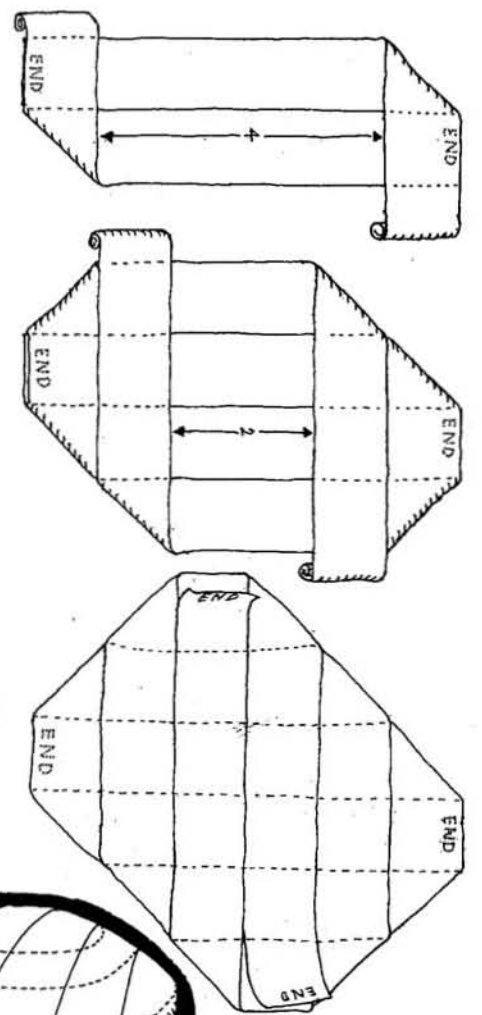

2(1x23) STRIP PILLOW

tetrahedron

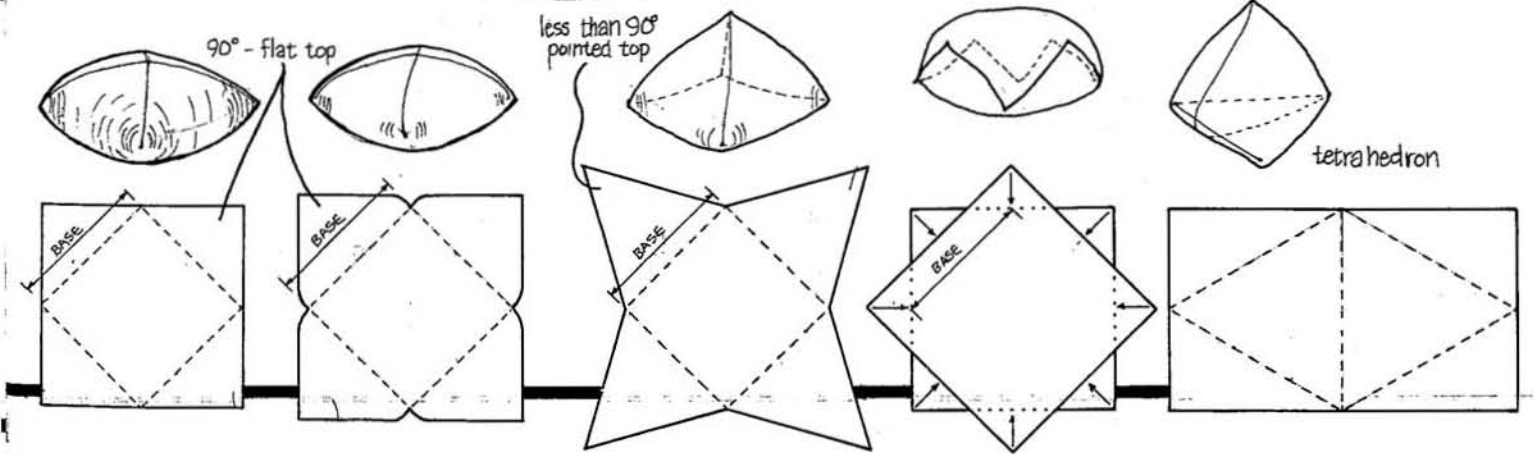

MATERIALS

MATERIALS

We used polyethylene because of low cost and easy handling. With a material as abstract as a micro-thick plastic film, and as easy to join as polyethylene, one can transit the entire design-then-build process in such a short time as to be able to see the process as a whole. In this sense polyethylene can be a medium for learning about whole design processes.

POLYETHYLENE — (dictionary definition) impervious to moisture, lighter than water, tough, pliable, outstanding at dielectric high frequencies; excellent chemical resistance.

We started out using four mil (.004") for everything (it's cheapest) but now we use 6 mil wherever we can — 6 mil strikes a pretty good balance between cost and longevity. The lifespan of the membrane depends on 1) the surface the bubble will sit on (grass is best) 2) what the wind will do to it (High winds may destroy the plastics just by the force of the wind, but more often the damage is done by the wind ripping the poly on branches, corners of things, etc.); 3) the use it is put to. Public events with high energy sources such as rock music tend to wear hard — stable uses such as greenhouses or sleeping places tend to wear well. Under optimum conditions (minimum sun & wind) the material should last about a year. 4) (for public places particularly) understanding of the nature of the material by the people using it. Users need to be made aware, somehow, to take off their shoes before entering, not to walk on (through) the walls, not to tear the doors as they go through, and not to block the air-supply tunnels. Generally we try to reinforce areas of heavy usage and make air tunnels where you can't get to them or make them big enough to crawl in without blocking the air flow. It's better to design in durability than have to police the vulnerable details (e.g., self-closing doors in Geometry section).

COLOR or: COLOR

The most easily available colors are clear and black (used in concrete construction work) but white and colored poly can also be found. Clear is decidedly magical. Its drawbacks are that it gets tremendously hot inside if there is sun and it is a hot day. It can cook the people inside and the grass underneath. This can be turned to good advantage in cool weather for solar heat or, in warmer weather good for water environments, sauna baths, oil massages, etc. Be careful of leaving a clear bubble on a green lawn for too long as it will steam the grass in its own juice in a few hours if the sun is hot. White reflects heat, but it gets very bright inside. You can project on it at night or bounce colored lights around inside it. One good design compromise is a half white/half clear bubble — you can put the white side up to the sun or the clear side up on cool or cloudy days. It's best to find shade, or bring your own — a big parachute over a bubble helps a great deal on hot days. Frosted poly is best for rear projection, white for front projection (although white will work for rear projection — it just isn't quite as bright an image). Some poly sold as clear is what is called "natural" which is slightly frosted, although not frosted enough to work well for rear projection. With usage, clear becomes frosted — you can facilitate the process by rubbing it until the static charge picks up dust. Colored poly gives a fine colored light inside. Sources for colored poly are 1) sheetrock and some other building materials are shipped on flatcars covered with 20' X 50' sheets of colored poly. Talk to the people who unload the cars. Once we got a brand new red cover from the US Gypsum factory in Houston. 2) Colored poly dropcloths from paint or hardware stores. 3) Manufacturers of gas station and used car lot banners. Bergman Banners in San Francisco stocks nine colors in 36" width (4 mil) and sells it for \$.03/sq.ft. 4) Union Carbide will make any color for you in lots of 5,000 lbs. It is possible to buy colors that they already have in 1,000-lb. lots.

Building supply stores are the most widespread sources of polyethylene (good last minute, Saturday sources) but packaging houses and concrete construction supply companies usually are cheaper and carry a larger stock of different weights and sizes of black and clear. They can usually order white (in San Francisco area, the Visqueen distributor has white).

Best prices we've found in the San Francisco Area (per sq.ft.)

WEIGHT	CLEAR	WHITE	BLACK
4 mil	1¢	2¢	1.1¢
6 mil	1.5¢	N.A.	1.6¢
8 mil	2¢	N.A.	2.2¢

(Note: Prices in San Francisco aren't low for building materials. Price per square foot doesn't seem to increase for larger size pieces. White only comes in 4 mil.) Also see attached Sears price list.

TAPE or: TAPE

Polyethylene can be heat-sealed, but we use tape because it eliminates hardware, can be used in the field, and the technique can be mastered by large numbers of people. The most common kind of tape is 2" poly tape available from most polyethylene outlets, but it's not the best. Good tape comes in wider sizes, and is much stronger (if the seam is taped well, the poly will rip before the seam).

Tape can be had from:

Arista Custom Tape Co.
Foot of Farm Rd.
Secaucus, N.J. 07094
864-3131

Mr. Zimmier is a fine guy. He doesn't like to fill orders smaller than \$100. He can send an order by UPS air freight to San Francisco in three days. He will cut his 9 mil vinyl tape (for use on polyethylene) to any width. Price is \$1.20/inch of width for a 36 yd. roll in any color except clear (which comes in 4" only and is about \$4.50/roll). The 4" clear stuff is very good for on the spot patching. 3" width is good in the colored tape.

Jim Cook (who has a good deal of experience in poly inflatables which he is usually pretty open to sharing) sells 4" wide polyethylene tape (36 yd rolls) which is also excellent tape. The price is comparable to Arista's on 4" clear but the service isn't quite as fast.

H. T. McGill Co.
P.O. Box 517
4511 Front St.
Brookshire, Texas
77423

Let us know of any other good sources and we will publish the info.

SAFETY CODES AND THE FIRE MARSHALL

From Tensile Structures, Volume One by Frei Otto: "... pneumatic buildings are safer than any other form of structure. The main advantage of the pneumatically stretched membrane is its small weight; even with spans of more than 100m, the weight of the structure does not exceed 3kg/sq.m. Even if the compressed air supply should fail, it would take a long time for large envelopes to collapse, since the enclosed air can leak out only slowly. Even large holes and tears are not dangerous. Although the pressure drops quite rapidly, the force due to the weight of the membrane is so small that, in large envelopes, it may take days before the enclosed air escapes even if the openings are large." We've never had any injuries due to structural failure.

Fire codes are necessary, witness circus tent fire tragedies. They are usually primarily concerned with exits in public structures. Polyethylene inflatables have a virtual 360' exit because anyone can rip his way out, but this is sometimes hard to communicate to a fire marshal because he will have no precedent for allowing that type of exit. He will also want to test the fire resistance of the membrane itself, usually by holding a small piece of it over a bunsen burner for ten seconds, then removing it. If it remains burning for more than two seconds it is not considered self-extinguishing. However, when the polyethylene is inflated, the structure has internal pressure which works to extinguish the flame as soon as it burns through the membrane. (Charley Tilford in New York has done some research on this and has a film of his efforts.) Try to explain this. We put up inflatables in many public situations with mixed success - we did not get approval from the San Leandro Fire Marshal for Stewart Brand's hunger show, but we did get approval (with the diligent aid of Dr. Frank Oppenheimer) for an intermedia event in the Palace of Fine Arts in San Francisco. We didn't consult a fire marshal before Altamont, but remember you are responsible for the safety of your structure.

Good things to talk about with Fire Marshalls:

- 1) self-extinguishing properties of inflated polyethylene
- 2) rip through exit doors (thinness of the poly)
- 3) the huge number of doors you have
- 4) length of time required to deflate the building with holes in it
- 5) the pressure at which the buildings runs
- 6) the number of CFM of air you are providing per person
- 7) how powerful your back up fan is (this is a must for public events)



CONTACT PAPER (the stuff you put on shelves)

It's good reinforcing for places that get heavy stress or traffic, like doors and where tunnels join floors.

REINFORCED POLY

(See Sears catalog page.) This is fine, strong stuff, although a little difficult to tape due to texture. There is also a company in Houston named Griffolyn that produces this stuff. I don't know how their prices compare.

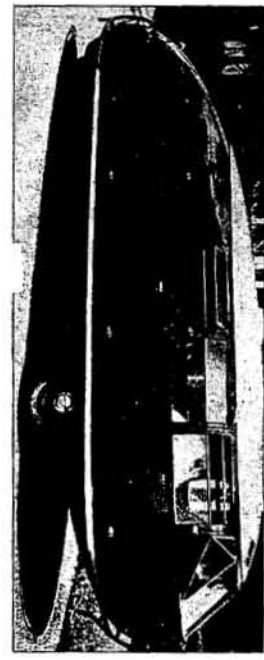

TAPING PROCESS or: TAPING PROCESS

This is best worked out by you, partly depending on the number of people you have taping together. AVOID WRINKLES in the tape as the wrinkles will gather water, particularly when the bubble is left uninflated in the rain. This will eventually destroy the bond of any of these tapes.

HEAT SEALING

Someone from Oregon sez: You can seal poly with a regular clothes iron (Teflon if possible). The quality of the seam varies greatly with the skill of the person who is seaming, so practice first. I saw a dome bubble that got destroyed by the wind as the seams had been heat-sealed this way by amateurs. Put a couple pieces of cardboard together upright under the overlapping edges and run the iron along it smoothly and evenly.

POLYESTER (mylar is a trade name for polyester)

Silvered mylar is a good reflective surface and VERY magical. 2 mil mylar is roughly equivalent in strength to 6 or 8 mil poly, and it can be taped together like poly. John Reeves in Boston got a quantity of it from Eiser Industries in Revere, Mass. for \$.20/sq.ft. He had to do a lot of talking to get it at that price. There are a lot of companies producing mylar now, but we haven't investigated. Again, let us know what you find out.

MATERIALS

RECYCLING

The best way to recycle polyethylene is to reuse it, but when it gets many holes in it, it is no longer good as a rain cover. The worst thing you can do with it is to put it in a garbage can — it will probably end up as land fill and never decompose. The best thing you can do with it is BURN it. When polyethylene burns it breaks down into CO₂, H₂O, and carbon which is the ugly black smoke produced but which will precipitate out of the air quickly and be absorbed by the earth.

It is possible to recycle poly chemically, but it's an elaborate process and all the big manufacturers find it more profitable to make it from fresh natural resources (petroleum). We think inflatable shelter is a much better use for petroleum than burning it in an internal combustion engine. We also like inflatables because they aren't in any one place long enough to leave marks on the earth after they're gone.

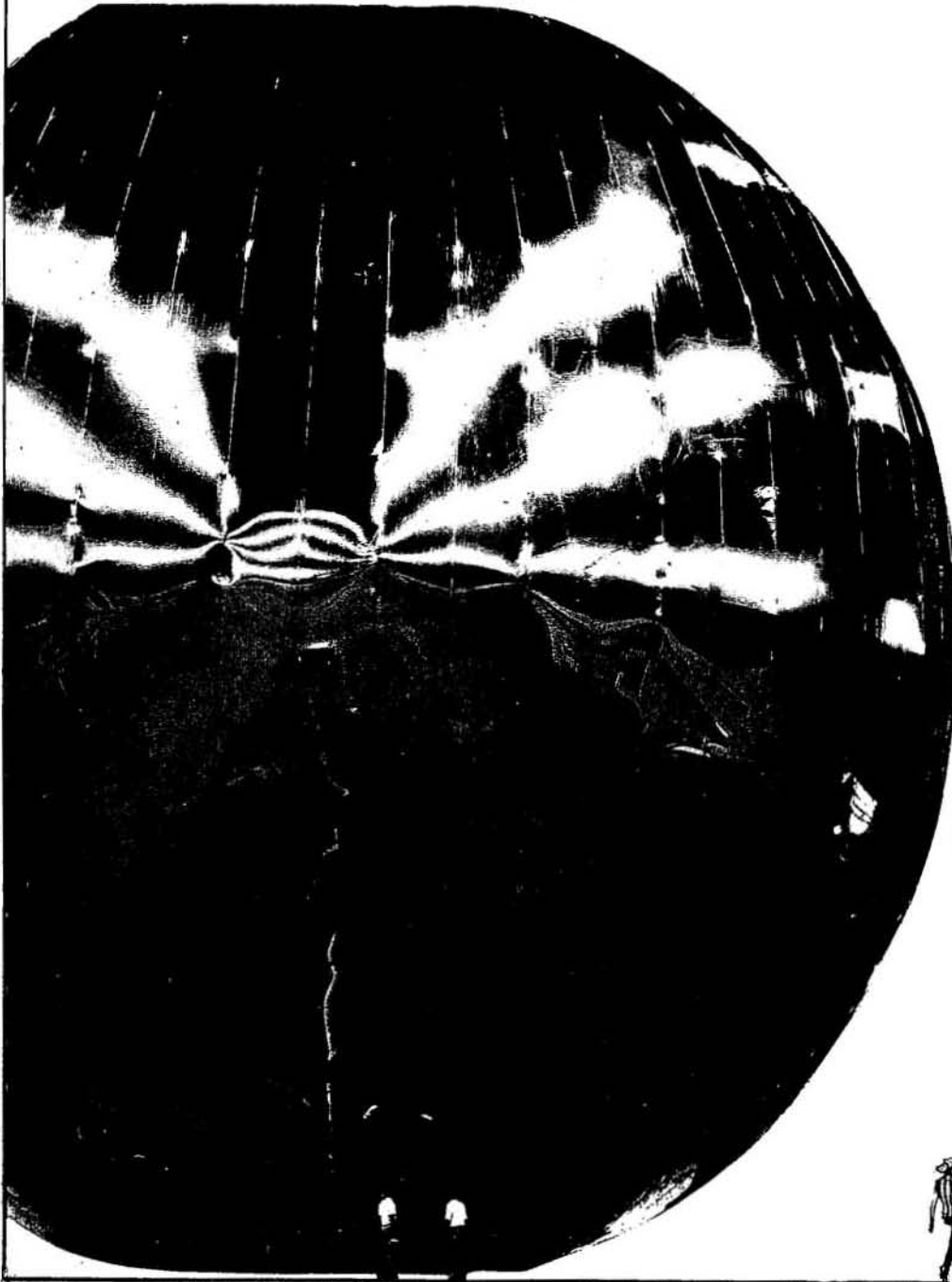

Vinyl is a lot SOFTER
and a lot TOUGHER !!

In a nutshell..... Advantages
of polyethylene CHEAP cost per sq.
3/4¢ ~ 2¢ per sq. ft. Built - 40¢/sq.
low tech poly tapes together, easy to tear
building technique to others - build your
ON SITE ASSEMBLY poly tapes together
Vinyl lasts longer (2
vinyl can be fireproof (poly isn't) Vic
structures will withstand greater winds,
temperatures (80 mph winds; 30° below)
Vinyl costs 30¢ to 2\$/sq-ft.
(reinforced)
Vinyl building 80¢ to 3\$/sq-ft.



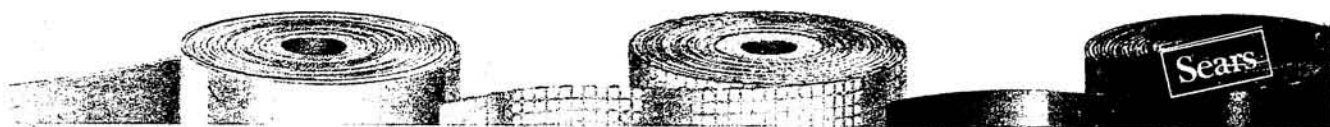

Clear Polyethylene

Less than **1c** sq. ft.—4 mil*
10x50 ft. roll

Lasts indefinitely when out of light... about 6 months in direct sunlight. Meets FHA requirements and Dept. of Commerce wt. specifications. Rotproof and water resistant. Remains flexible to 70° below zero. Not for greenhouses.

Thickness	Width	Length feet	Catalog Number	Wt. lbs.	Roll
4 mil*	3 ft.	50	32 W 42006C	4	\$1.57
	4 ft.	50	32 W 42008C	5	1.98
	6 ft.	50	32 W 42011C	7	2.79
	8 ft.	50	32 W 42014C	9	3.75
6 mil*	10 ft.	25	32 W 42016C	5	2.79
	10 ft.	50	32 W 42017C	11	4.79
	12 ft.	50	32 W 42021C	13	5.69
	16 ft.	50	32 W 42024C	17	7.55
	20 ft.	50	32 W 42027L	21	9.50
	6 ft.	50	32 W 42055C	9	4.25
10 ft.	50	32 W 42061C	15	6.98	
12 ft.	50	32 W 42064C	17	8.50	
20 ft.	50	32 W 42072L	31	13.95	

More PRICE ROLL-BACKS!

100-foot rolls. Clear Polyethylene.

Thickness	Width	Catalog Number	Wt. lbs.	Roll Was	Roll
2 mil*	8 ft. 4 in.	32 W 42003C	9	\$3.75	\$3.56
	3 ft.	32 W 42007C	7	2.69	2.55
	4 ft.	32 W 42009C	8	3.65	3.46
4 mil*	6 ft.	32 W 42012C	13	5.29	5.02
	8 ft.	32 W 42015C	17	7.09	6.73
	10 ft.	32 W 42018C	22	8.99	8.54
	12 ft.	32 W 42022C	26	10.59	10.06
6 mil*	16 ft.	32 W 42025C	34	14.25	13.53
	20 ft.	32 W 42028L	43	17.95	17.05
	6 ft.	32 W 42056C	17	7.95	7.55
	12 ft.	32 W 42065L	34	15.95	15.15
10 mil*	20 ft.	32 W 42073L	59	26.35	25.03
	20 ft.	32 W 42086N	96	45.95	43.65

**Was prices from 1970 Spring Big Book

Super-clear Vinyl 5²/₃c sq. ft.—4 mil* 3x100-ft. roll

2 to 3 times stronger than polyethylene. Stands up to sun... ideal for storm windows. Highly tear resistant. Stays flexible to -26° F. Not recommended for permanent greenhouses.

Thickness	Width	Roll length	Catalog Number	Shpg. wt. lbs. oz.	Price
4 mil*	3 ft.	per ft.	32 W 42281C	2	20c
	3 ft.	25 ft.	32 W 42282C	3	\$4.65
	3 ft.	50 ft.	32 W 42283C	6	8.65
	3 ft.	100 ft.	32 W 42284C	12	16.25
	4 ft.	per ft.	32 W 42285C	3	27c
	4 ft.	25 ft.	32 W 42286C	4	5.99
4 ft.	50 ft.	32 W 42287C	8	11.25	
4 ft.	100 ft.	32 W 42288C	16	21.50	

Mesh-reinforced Plastic

9x10-mesh low as **11¹/₃c** per square foot
2-ft. 4-in. x 100-ft. roll

Steel-reinforced. Woven wire mesh, non-ravel edges, electrogalvanized, coated with liquid cellulose acetate. Bursting strength of 9x10 mesh is 109 lbs.; of 14x14 mesh 157 lbs. Lasts several seasons. Cut with scissors.

Mesh	Width	Roll length	Catalog Number	Shpg. wt. lbs.	Price
9x10†	2 ft. 4 in.	25 ft.	32 W 42827C	7	\$7.25
		100 ft.	32 W 42829C	23	25.95
	3 ft.	25 ft.	32 W 42831C	9	8.95
		100 ft.	32 W 42833C	29	33.50
14x14†	2 ft. 4 in.	25 ft.	32 W 42835C	11	11.75
		100 ft.	32 W 42837C	35	32.50
	3 ft.	25 ft.	32 W 42839C	12	11.25
		100 ft.	32 W 42841C	41	41.95
4 ft.	25 ft.	32 W 42843C	16	14.75	
		32 W 42845L	16	14.75	
	100 ft.	32 W 42847C	29	28.25	
		32 W 42849L	29	28.25	

†Wires or strands per square inch

Cotton-reinforced Low as **6c** square foot

Green cotton 4x4 mesh, multiple strands woven for extra strength, fused between 2 sheets of cellulose acetate plastic. Total thickness 1.76 mil*. More flexible than metal reinforced plastic. Ideal for curved installations. Holds its shape yet stays pliable even at low temperatures. Keeps cold out, heat in. Cut with scissors.

Mesh	Width	Roll length	Catalog Number	Shpg. wt. lbs.	Price
4x4†	3 ft.	25 ft.	32 W 42816C	3	\$4.50
		50 ft.	32 W 42817C	5	8.45
		150 ft.	32 W 42819C	12	23.95

†Wires or strands per square inch

Black Polyethylene

4 mil* less than **1c** square foot in
10x50-ft. roll

Won't rot or mildew. Keeps out damaging light, ultra-violet rays. Lasts 3 to 5 times longer in sunlight than clear polyethylene. Salt-proof, paint-proof, oil-proof... can't be damaged by corrosive compost or silage acids. Cut to size with scissors. Available in 6 to 40-ft. widths.

Thickness	Width	Length feet	Catalog Number	Wt. lbs.	Roll
4 mil*	6 ft.	50	32 W 42108C	7	\$2.88
	10 ft.	50	32 W 42111C	11	4.69
	10 ft.	100	32 W 42112C	22	9.15
	16 ft.	16	32 W 42116C	6	3.59
	16 ft.	50	32 W 42118L	17	7.55
	16 ft.	100	32 W 42119L	34	14.75
6 mil*	20 ft.	20	32 W 42122C	9	5.59
	20 ft.	50	32 W 42124L	21	9.65
	20 ft.	100	32 W 42125L	42	18.75
	28 ft.	100	32 W 42131N	58	27.25
	10 ft.	50	32 W 42155C	15	7.10
	10 ft.	100	32 W 42156C	29	13.85
6 mil*	16 ft.	50	32 W 42161L	24	11.25
	16 ft.	100	32 W 42162L	48	21.95
	20 ft.	50	32 W 42165L	31	14.35
	20 ft.	100	32 W 42166L	60	28.25
10 mil*	28 ft.	100	32 W 42168N	90	39.75
	32 ft.	100	32 W 42171N	100	45.50
	40 ft.	100	32 W 42174N	127	56.75
10 mil*	20 ft.	100	32 W 42181N	96	47.00

Black Plastic Mulch *1.99 104-foot roll

Prevents weed growth, ends need to cultivate. Increases yield because it speeds germination. Helps prevent frost damage... maintain even ground temperature. Won't rot. Can be stored wet. Durable, 1/4-mil* thick, 40. inches wide. Available in 104 and 1000-foot rolls. 32 W 42101C—104-ft. roll. Wt. 3 lbs. Roll \$1.99 32 W 42102C—1000-ft. roll. Wt. 25 lbs. Roll \$11.89

Utility Plastic for windows, floors, carpets

(1 and 2) Milk-white translucent film. 30 inches wide. Gives frosted effect on bathroom windows, shower doors. Ideal for temporary carpet runners. Diamond embossed film (1) has greater slip resistance, ribbed film (2) is more pliable; both types can be easily cleaned by shaking. Sold per foot or in 100-foot rolls.

- 1 Diamond Embossed Film. Per ft. Shipping wt. 4 oz. 32 W 42275C.....Foot 34c Roll. Shipping weight 24 lbs. 32 W 42276C.....\$30.95
- 2 Ribbed Film. Per ft. Shipping weight 4 oz. 32 W 42271C.....Foot 23c Roll. Shipping weight 21 lbs. 32 W 42272C.....\$19.95

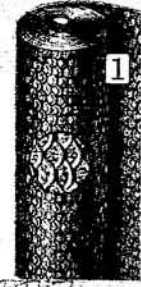

Cover Outfits

Low as **\$2.49**

Polyethylene... flexible, pre-cut plastic sheeting of 6 mil* thickness with 4 1/2 x 2 in. brass grommets (3/8 in. diam.), self-adhesive tie downs. Protects most anything from weather, dust, grease.

Color	Size feet	Sq. ft.	No. ties	Catalog Number	Wt. lbs.	Price
Clear	20x50	1000	40	32 W 42071L	33	\$17.75
	6x9	54	10	32 W 42579	2	2.49
	9x12	108	12	32 W 42581	3	3.59
	10x20	200	16	32 W 42582	6	6.75
	15x20	300	18	32 W 42583	10	9.75
Green	20x20	400	20	32 W 42584	12	11.95
	20x40	800	28	32 W 42585C	23	19.95

- 3 Heavy-duty Indoor-Outdoor Tape for smooth surfaces. Clear 10-mil* polyethylene. Air-tight, waterproof. 50 ft. roll. 1 or 2-in. widths. 32 W 42915—One in. width. Wt. 4 oz. Roll 79c 32 W 42916—Two in. width. Wt. 10 oz. Roll \$1.39
- Indoor-Outdoor Waterproof Cloth Tape. 60-ft. 32 W 42914—One-in. width. Wt. 6 oz. Roll \$1.19
- Double-faced Mounting Tape. Strong ivory paper with adhesive backing on both sides. 54-ft. roll. 32 W 42911—3/4-in. width. Wt. 4 oz. Roll 79c
- Aluminized Plastic Cloth Tape. Waterproof. Makes excellent sealant for air ducts, joining or mounting plastic sheeting. 60-foot roll. 2-in. width. 32 W 42921—Wt. 1 lb. Roll \$1.65

- (4 and 5) Snap Fasteners. Snap covers on and off quickly. Crowns on 2x2-inch pressure sensitive tape. Studs on tape or wood screws. 10 each per pkg.
- 4 Tape-mounted studs for smooth surfaces. 32 W 42903—Pkg. of 10. Wt. 4 oz. Pkg. 99c
- 5 Screw-in Studs for rough surfaces. 32 W 42904—Pkg. of 10. Wt. 4 oz. Pkg. 99c
- 6 Brass Grommets Plastic Tie Downs. Pressure-sensitive adhesive. 4 1/2 x 2 in. 32 W 42902—Pkg. of 10. Wt. 4 oz. Pkg. 99c
- 7 Molding Strip. Resin treated cardboard, tacks. For mounting sheeting. 3/8 in. by 36 in. long. 32 W 42905—Pkg. of 18. Wt. 1 lb. Pkg. 55c
- 8 Button Stakes for anchoring plastic covers to ground. 6 in. long, notched. Pkg. of 40. 13 W 19921—Shipping weight 6 ounces. Pkg. \$1.25

*How thick is a mil? One mil is one-thousandth (.001) of an inch... 2 mil. about as thick as this page.

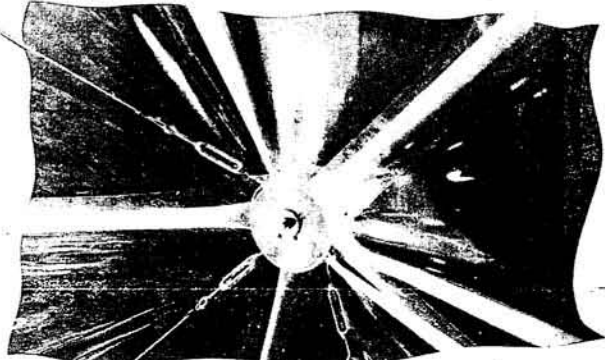

Sears

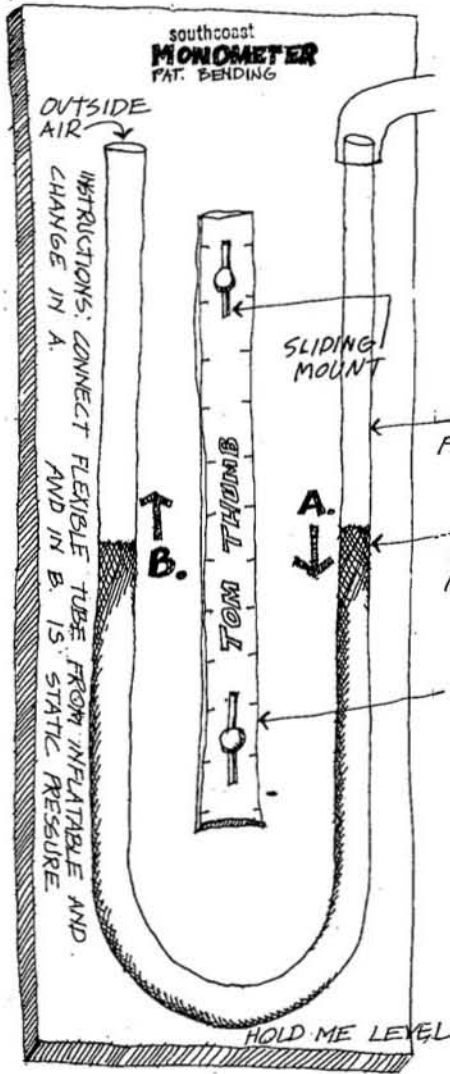

Since polyethylene is so light (1200 sq.ft. of 4 mil weighs about 20 lbs.) a fan usually is a better air source than a blower. A blower gives more pressure than is necessary to support the weight. Blowers tend to be high-pressure low-volume air sources; fans give out more air at lower pressure. In measuring the output of a fan or blower there are two considerations: number of cubic feet per minute (CFM) of air delivered and the static pressure at which that air is delivered. A water manometer is an easy way to measure static pressure.

A manometer will give you a lot of interesting and useful information about your bubble. Wind effects, for example, do not always increase the pressure inside the bubble (see Anchoring section). You can tell how much pressure your seams will withstand. Make your seams strong enough to withstand 2/5" pressure, because windloading is best withstood by maintaining a tight skin. If the skin isn't tight, the wind will make a sail in the side of the bubble and then you are at the wind's mercy . . .

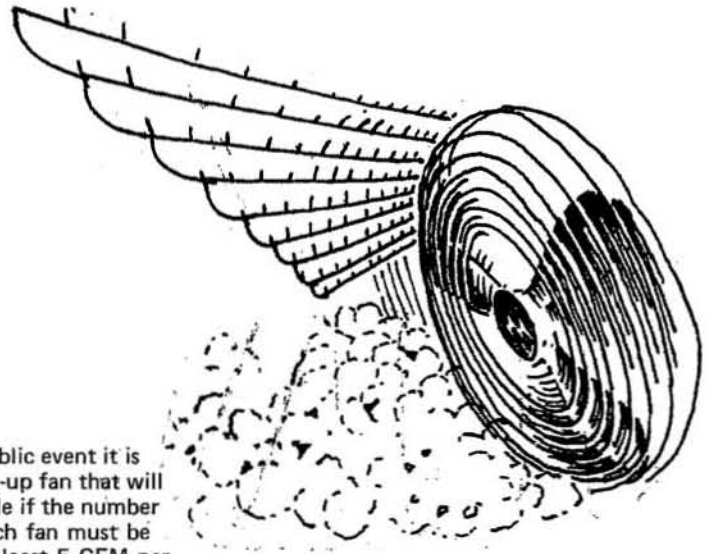

Remember that for a public event it is necessary to have a back-up fan that will support the whole bubble if the number one fan should fail. Each fan must be capable of supplying at least 5 CFM per person inside the bubble. Having a working generator on hand is a good idea if your power source is at all dubious. (We have panicked when a fuse inside a locked building blew.)

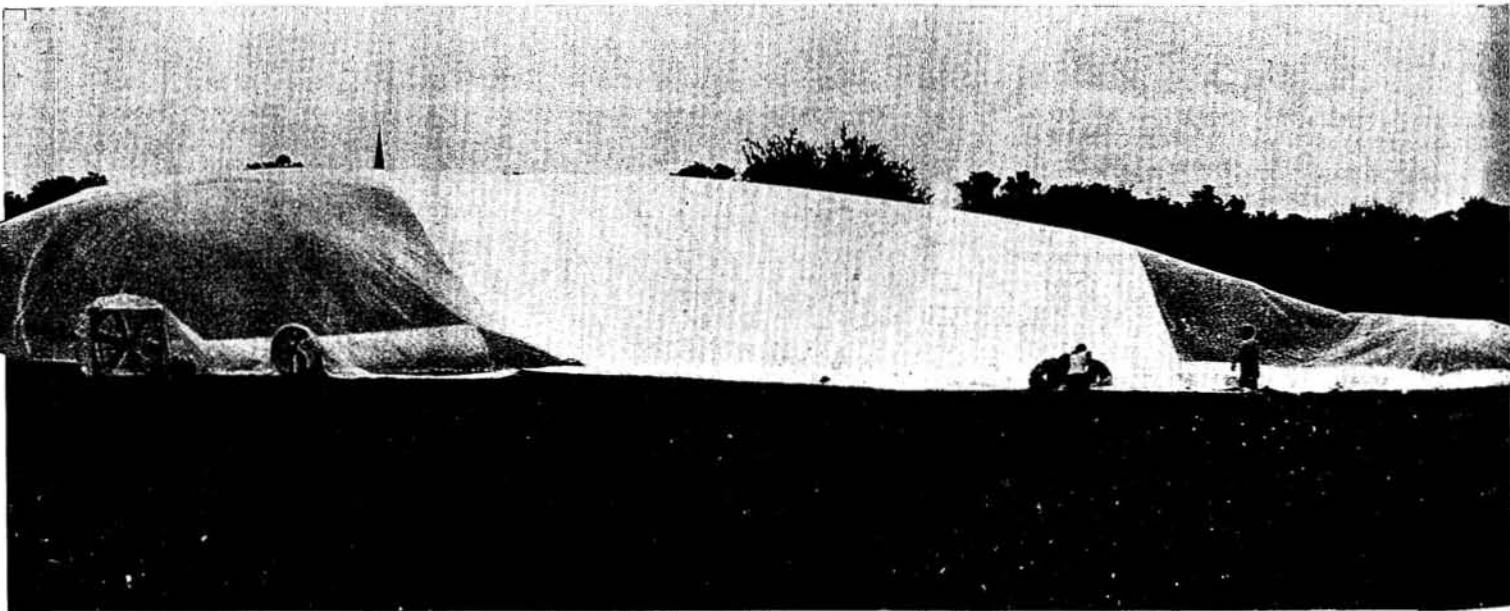

This is the 100' pillow before we put a net on it. When it was half inflated, we stopped inflating it to patch up the little strings we had taped to it for tie-downs. A storm blew up and the wind made the 40' X 100' sail that you see in this picture. All the little strings popped and the bubble took off. We finally stopped it by cutting a 60' slit in the back side to release all the air. Imagining a sail boat with a sail that big will give you an idea of the magnitude of force involved. This was an extreme case of low pressure, but you get the idea . . .

AIR SUPPLY

A good source of fans and specifications on fans is Grainger's (a national chain of wholesalers). They sell a large variety of fans and blowers, each one listed in the catalog with its output. I usually try to match up a used fan I am buying with something in their catalog for an output estimate. To get a catalog or buy from them you have to show some company credentials or a purchase order, but it is worth the hassle as their prices are about 1/2 to 3/5 retail. A new fan is usually cheaper than a used one in the long run if you get it wholesale, but any fan you can get for free can be made to work. (Beware of used fans for public events, though, unless you are sure the fan is good.)

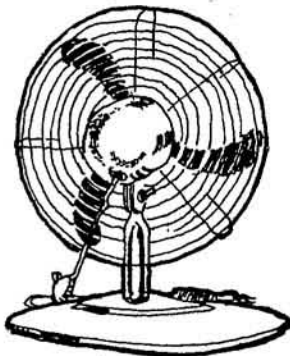

delivery tube

About the best fan we've used for medium-sized inflatables is Charley Tilford's old-time office fan that he talked the city of New York out of when they air-conditioned some offices. This fan is a 24" diameter, 1/4 h.p., direct-drive, two-speed fan with a cast-aluminum, three-prop air-foil blade and a sturdy, close-mesh guard. This fan probably put out about 5,000 CFM at 0" pressure and maybe 4,000 at 1/4" pressure. Having a strong guard on any fan is important if there are going to be any general public, little kids, or stoned people.

Charley cut down the pedestal so that the fan was near to the ground for more stability. The easiest way to attach the air tunnel to this type of fan is to tape it directly to the blade guard (another reason for a strong guard). Since the building will probably move around — especially if there is no net and the bubble is on a hill or in the wind — it is a good idea to make the air supply tunnel long enough so that the building can move without pulling the fan over. We've lost some good fans this way. (A good invention might be some skids on the bottom of your fans.)

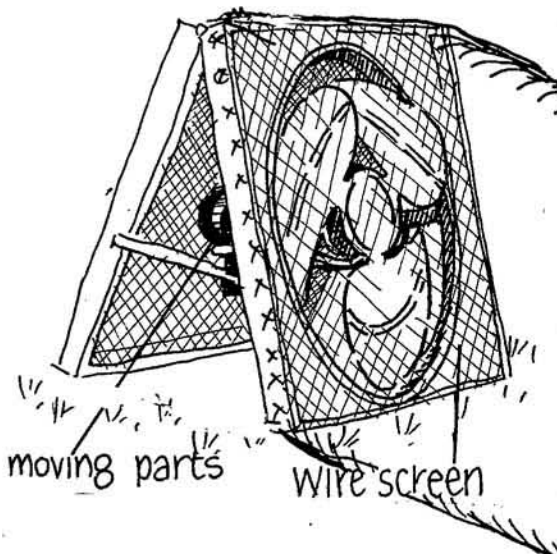

Our best fan for large bubbles (used on the 100' pillow) is a four-foot diameter, six-blade attic fan powered by a 3/4 h.p. motor. We scrounged this fan from a house that got air-conditioned. The original motor (1/4 h.p.) got burned out by a faulty generator, so test your voltage . . . if at all possible. If you are renting a generator get the rental place to test it for you. The replacement 3/4 h.p. motor we got (and all the fans and blowers we've gotten since) has overload protection. This is simply a device inside the motor that shuts the motor off automatically when the motor overheats (due to overloading, incorrect voltage, etc.). The page from the Craftsman Motor Selection and Installation Guide shows how motor speed relates to fan speed determined by pulley sizes. This is a good booklet you can get from Sears. (HOW TO SELECT AND INSTALL ELECTRIC MOTORS) The attic fan puts out about 15,000 CFM at 0" and very approximately 12,000 at 1/8". A STRONG mesh guard highly recommended. 1/2" screen is good. (Hinge pins are removeable for transporting.)

Charley recommends this fan for medium to big inflatables. This frame is made with electrical conduit. Included are the specs for this fan from the Grainger catalog.

12" TO 24" VENTURI-FRAME EXHAUST FAN KITS

1200 to 6800 CFM. 1 & 2-Speed Totally Enclosed Dayton Motors. Aluminum Blades

16" FAN
\$27.69
Lots 5, Up

Assemble this 3-part kit and you'll have a top-efficiency exhaust fan at a saving up to 30%. This venturi-frame preferred everywhere because of ease of installation and efficient ventilation. Kit comes complete. Totally-enclosed Dayton 1500 RPM shaded pole or 1725 or 1725/1140 RPM split-phase, 115V, 60 Cy. motors. Motors rubber

mounted for quiet performance. Quiet, Dayton 3-wing aluminum fan blade. Rigid steel fan frame with venturi discharge. Adjustable pre-punched motor base fastens to vertical supports with U-bolts supplied. Panel has mounting hole in each corner for easy, secure mounting. Hardware kit included. Panels are 4" wider and higher than fan blade size. For shutters, see index.



WARNING:
FUNKY GENERATORS
EAT FAN MOTORS

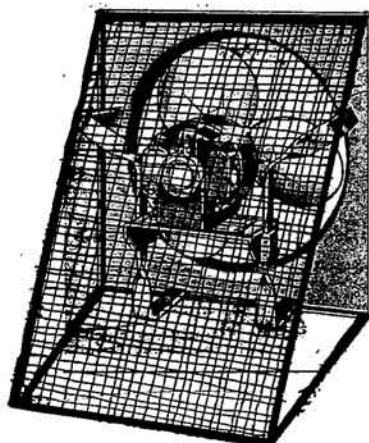

Blade Dia.	RPM	CFM	Mtr. HP	Stock No.	Retail	Knocked-Down Each	Shpg. Lots 5	Wt.
12"	1500	1200	1/20	7C867	\$30.30	\$18.12	\$17.53	13
16"	1725	2820	1/4	7C527	47.40	28.38	27.69	81
	1725/1140	2820(†)	1/4	7C528	65.75	39.37	38.68	85
18"	1725	4040	1/4	7C529	49.35	29.53	28.79	32
	1725/1140	4040(†)	1/4	7C530	67.70	40.52	39.78	36
	1140	3080	1/6	7C535	81.45	36.80	36.06	32
20"	1725	4350	1/4	7C531	50.75	30.38	29.54	34
	1725/1140	4350(†)	1/4	7C532	69.10	41.37	40.53	38
	1725	5000	1/3	7C642	55.50	33.22	32.38	37
	1725/1140	5000(†)	1/3	7C868	74.50	44.60	43.76	40
24"	1140	4350	1/6	7C536	62.90	37.65	36.81	34
	1725	5150	1/4	7C087	53.15	31.83	30.94	41
	1725/1140	5150(†)	1/4	7C327	71.50	42.82	41.93	46
	1725	6800	1/2	7C873	71.65	42.89	42.00	52
	1140	4600	1/6	7C088	65.30	39.10	38.21	43

(†) CFM on low speed approx. 1/3 less.

A belt should be just tight enough so that finger pressure midway between pulleys will deflect it about 1/4 inch. If too loose, slippage of the pulleys will wear it out. If too tight, it increases motor load and wear on the bearings.

SELECTING PULLEYS

V-pulleys are measured from edge to edge (*not in groove*). The following table gives you the speeds of driven pulleys when using various combinations of drive and driven pulley sizes (in inches).

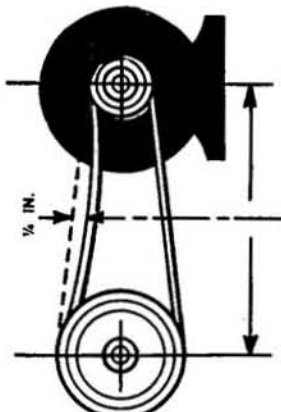

DRIVEN PULLEY SPEEDS IN RPM

DIAM. MOTOR PULLEY	DIAMETER OF PULLEY ON MACHINE, INCHES									
	1 1/2"	1 3/4"	2"	2 1/4"	2 1/2"	3"	3 1/2"	4"	4 1/2"	5"
1 1/4"	1725	1425	1230	1075	950	850	715	540	430	330
1 1/2"	2075	1725	1475	1290	1140	1000	850	645	515	395
1 3/4"	2400	2000	1725	1500	1340	1200	1000	750	600	460
2"	2775	2290	1970	1725	1530	1375	1145	850	685	530
2 1/4"	3100	2580	2260	1990	1725	1550	1290	965	775	595
2 1/2"	3450	2870	2460	2150	1900	1725	1435	1075	850	660
3"	4140	3450	2950	2580	2290	2070	1725	1290	1070	800
3 1/2"	4500	3750	3250	2850	2520	2275	1900	1425	1200	900
4"	5000	4250	3750	3300	3000	2775	2295	1725	1500	1100
4 1/2"	5450	4650	4050	3600	3300	3075	2550	1900	1650	1250
5"	6000	5100	4400	3900	3550	3300	2750	2050	1800	1350
5 1/2"	6550	5500	4750	4200	3850	3550	2950	2200	1950	1450
6"	7200	6000	5200	4600	4200	3900	3250	2450	2150	1550
6 1/2"	7850	6550	5700	5050	4600	4300	3550	2700	2350	1700
7"	8500	7150	6200	5500	5050	4750	3900	3000	2650	1900
8"	9200	7870	6900	6125	5520	5200	4300	3350	2950	2150
10"	11000	9250	8100	7150	6500	6150	5100	4000	3550	2600
12"	13000	10900	9600	8450	7700	7300	6000	4700	4150	3000
15"	16000	13500	11900	10500	9600	9100	7500	5700	5000	3600
18"	19000	16000	14100	12500	11400	10800	9000	6700	5900	4300

* DRIVEN pulley speed based on use of a 1,725 rpm motor. For a 3,450 rpm motor double the speeds listed. The formula for figuring speeds is:

$$\frac{\text{Dia. of Drive Pulley} \times \text{Speed of Machine}}{\text{Dia. of Driven Pulley}} = \text{Speed of Motor}$$

PRECAUTIONS THAT WILL SAVE YOUR MOTOR

DON'T OVERLOAD MOTOR

Overloading a motor can burn it out. Don't expect it to run continuously overloaded.

DON'T LET VOLTAGE DROP

When voltage at motor drops, exactly the same thing happens as when the motor is overloaded. With too little "fuel" it is (in effect) overworked — heats up — and will burn out. Use ample size wiring.

DON'T 'SUFFOCATE' MOTOR

If free circulation of air to a motor is restricted (by dirt, rags or paper, or closing it up in a box) it overheats — may burn out. Keep motor clean, and dry. If used where wood chips, dust, etc. can enter inside, blow out the interior with dry compressed air — or use a vacuum cleaner.

GROUND MOTOR PROPERLY

The motor frame should be connected, by wire of same size used in line to motor, to a suitable ground (water pipes or a grounding rod properly installed) — both to protect you, and to protect the motor in case of an internal short circuit.

LUBRICATE MOTOR PROPERLY

Motors with bronze bearings do require occasional — but not too frequent or excessive — lubrication. It's best to check yearly, and add a few drops each time. Too much oil can cause trouble by getting out of the bearing into the motor.

USE RE-SET PROPERLY

If you have an overload protector with a manual reset button, always wait for motor to cool before using the re-set. Never hammer the re-set (if it seems to "stick"), as this will break off the switch parts. Any trouble with re-setting will probably be due to dust between the contacts — and blowing away the dust, or simply holding the button in firmly, will correct this.



We bought a huge centrifugal blower at the flea market, but the motor went out on us after only two events. The problems with used motors is that they only go out at crucial moments when there is the most strain on a motor, i.e., in a wind or when there are a lot of people going in and out. When you buy a used fan or blower, run it for 15 minutes first to see if it heats up. If this heats it up (hot to the touch), don't buy it, because if it heats up with no load, it is almost sure to burn out under strain. The wheel on this blower is about 12" X 12". We have used the 3/4 h.p. motor on this blower, which probably puts out around 3500 CFM at 0" pressure and 3000 at 1/4" pressure. It would probably pop the seams of any bubble if there were no air outlet (such as a door).

SIZING FAN

Figuring out what size fan to use, in a more thorough way than just referring to the chart. It involves taking into consideration all the demands on the fan. These are:

- 1) The pressure at which the bubble will be running. This is determined by the size and shape of the bubble in relation to the wind. This is dealt with in the "Anchoring" chapter. Running pressure is about 1 lb/sq. ft. (1/5" pressure in a water manometer). Under heavy wind as much as 2 lb/sq. ft. may be needed.
- 2) Heat calculations. Unless you have access to a giant heating or cooling system, your only controls over the temperature inside will be
 - a. color of the polyethylene — clear gets the warmest, white is coolest
 - b. shade — getting the bubble into the shade is by far the easiest and generally the most successful way to cool a bubble; frequently this is impossible, though
 - c. how much air you pass through the bubble — these calculations are primarily what we are dealing with below

- 3) How fast you want to inflate the bubble. It is unusual that you would want to inflate the bubble so fast that the size fan required would be larger than that required by the cooling requirements. But if you do use this as a design factor, take a rough estimate of the volume of the bubble (in cubic feet), divide by the number of minutes you want to take to inflate the bubble, and the quotient is the the required CFM output for the fan.

$$\frac{\text{Volume (ft}^3\text{)}}{\text{Inflation Time (min.)}} = \text{CFM required}$$

Inflation Time (min.)

ACCOMPANYING

The specifications we are trying to get for the fan can be expressed as a performance curve. All the figures being dealt with here are approximations, so you will have to adjust your bubble operating condition according to what feels right when the bubble is up (more holes, choking the fan tunnel with a string, etc.). This curve is different for each fan. We will give as an example here the approximate curve for the 24" Venturi-Frame Exhaust Fan from the Grainger catalog.

Using the given working pressure of a bubble to be 1" pressure (see "Anchoring") this particular fan will be putting out about 3500 CFM.

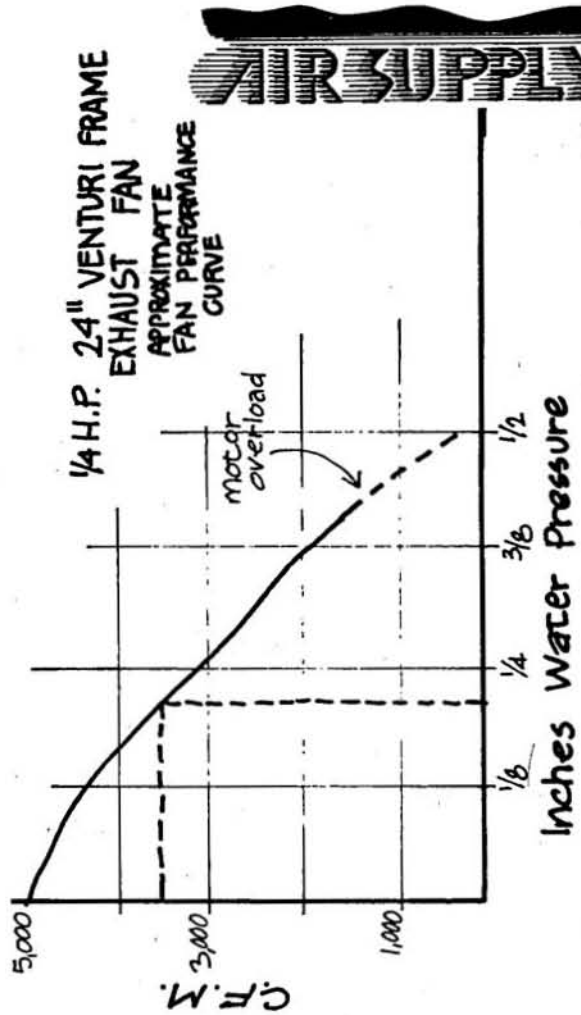

AIR SUPPLY



**! WARNING!
FUNKY GENERATORS
EAT FAN MOTORS**



FAN SIZING CHART

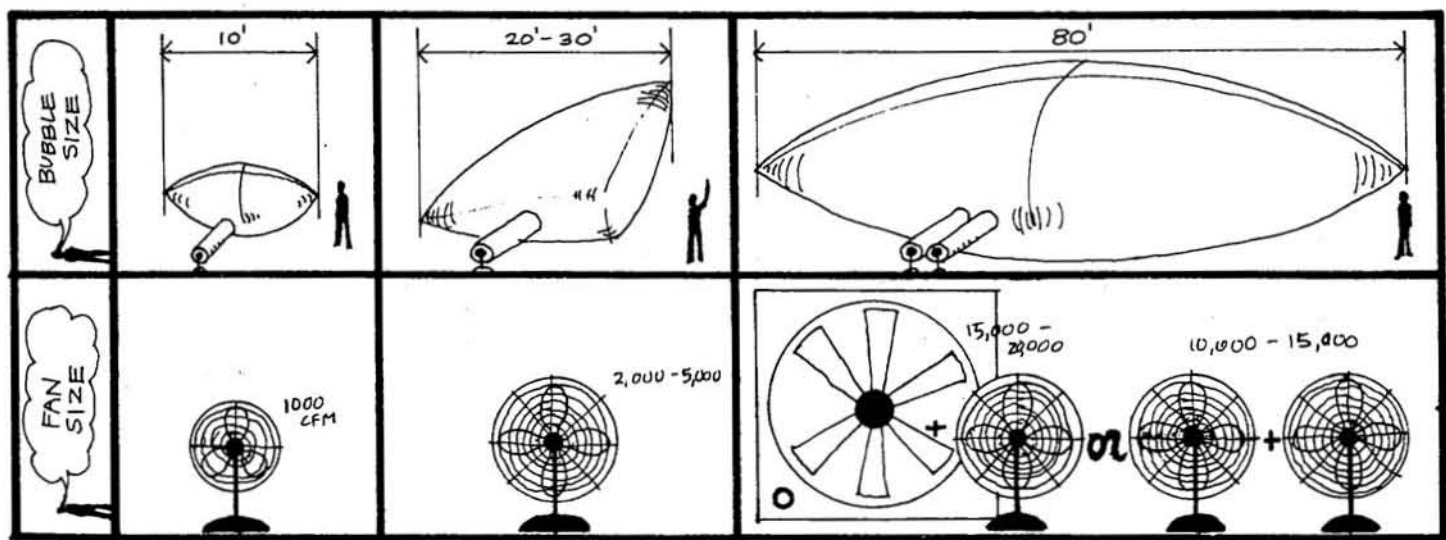

AIR SUPPLY

THESE ARE THE BLOWERS THAT HUDSON KUSTOMIZED FOR A TRAVELING THEATRE BUBBLE WE MADE FOR ALAN POTTER WHO'S NOW TRUCKING AROUND WITH IT AND HIS MEDIA VAN IN NEW ENGLAND. KUSTOMIZE YOURS FOR FUN & HANDLING- CONVENIENCE!!!

In order to arrive at how much air the fan is going to put into the bubble and how much area of holes it will take for this air to pass through the bubble while maintaining the proper pressure in the bubble requires a series of calculations. Since the amount of air we are going to pass through depends on the heating and cooling requirements, we must figure out what conditions are going to make it hotter and how much hotter, then balance this with the factors that are going to cool the bubble.

- HEATING FACTORS
- 1) sunshine
 - 2) people inside
- COOLING FACTORS
- 3) conduction through the bubble skin
 - 4) passing air through the bubble

How to figure these follows:



PHOTO BY E0JEL

1) HEAT GAIN DUE TO SUNSHINE

Heat gain due to sunshine is Very Approximately 300 BTU/sq.ft./hr. of direct sunshine (sun at 90 degrees to the surface of the bubble). Heat drops off towards sunset or as the angle the sun makes with the surface of the bubble diminishes.

It should be noted here that if you're using white polyethylene, which you should be if you are doing anything in the sun in hot weather, the heat gain will be somewhat less, but we will design for the maximum heat so we will have a little more cooling power than necessary rather than a little less. . . .

2) HEAT GAIN DUE TO PEOPLE INSIDE

Heat gain due to people inside is very approximately 400 - 1,000 BTU/person/hr. This depends on the level of activity of the people. If the bubble is going to be in full sun, this figure will be negligible compared with the heat gain due to the sun.

3) HEAT GAIN

3) HEAT LOSS DUE TO CONDUCTION THROUGH THE BUBBLE SKIN

$$Q = (A)(T)(U)$$

- Q = conduction loss in BTU/hr
- A = surface area of the bubble (not counting that which is one the ground)
- T = the difference in temperature inside and outside the bubble in degrees Fahrenheit
- U = heat transfer coefficient for polyethylene (about 1.2)

4) HEAT LOSS DUE TO PASSING AIR THROUGH THE BUBBLE

$$Q_{air} = (W)(C_p)(T)$$

- Q_{air} = heat loss in BTU/hr
- W = cubic ft. of air moved per hour
- C_p = heat capacity of air (about .016 BTU/ft³)
- T = difference between inside and outside temperature in degrees Fahrenheit

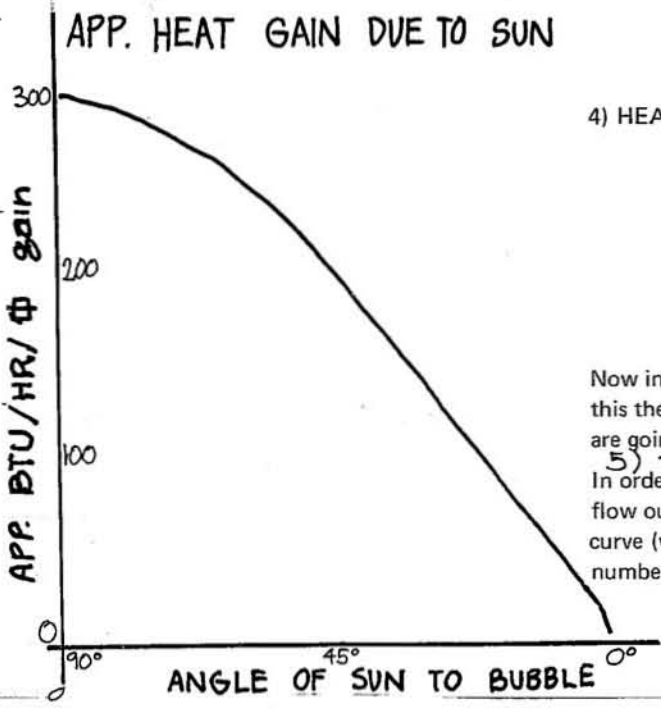

Now in order to use these figures, add together all the gains from heat and people, subtract from this the heat loss due to conduction, and solve the 4th formula for W or the amount of air you are going to have to move.

In order to pass this much air through a bubble, it is necessary to have some holes for the air to flow out. To get a rough idea of how big these holes should be, we will use the fan performance curve (which has been determined by the above figuring) figure obtained above for the required number of CFM to be moved, and the following formula:

$$P_d = \frac{(p)(v^2)}{2G}$$

$$P_d = \frac{(p)(v^2)}{2G}$$

- P_d = pressure drop at a hole (about 1lb./sq.ft. under normal conditions)
- p = density of air which is about .07 lbs./ft.³
- V = air velocity at the hole (in ft./sec.)
- G = acceleration due to gravity
- $2G$ = 64 ft./sec.²

V = (approx) 30 for normal conditions

Within the figures for V are the variables we are playing with:

$$V = \frac{\left(\frac{\text{CFM at which fan is operating}}{\text{square feet of opening}} \right)}{60 \text{ seconds}} \quad \text{(from calculation 4 above)} \quad \text{(the variable here to change minutes to seconds)}$$

LOOKS COMPLEX ?
NOPE, IT'S E-Z. HERES
AN EXAMPLE TO SHOW
YOU HOW. GO OVER
YOUR ASSUMPTIONS
(SUN ANGLE, ETC) AND
CALCULATIONS BEFORE
BUYING.

HYPOTHETICAL PILLOW DESIGN

for determining fan and size

EXAMPLE

50' X 50' pillow, white on top. To be used in daytime — maximum exposure to the sun will be about half the pillow getting 45 degree angle sun for noon hours. There will probably be about 100 people at medium to high activity as there will be rock music. Outside temperature is about 60° Fahrenheit — temperatures up to 80° F are acceptable inside. O.K. Little sketches are helpful for getting rough estimates so ...

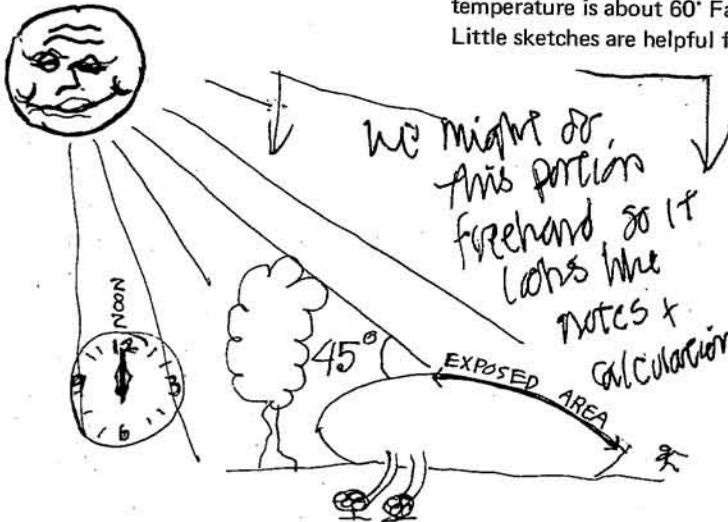

1) Sun Gain - 2500 sq ft
1250 sq ft exposed to 45 degree sun
(see chart) ~~xxxxxxx~~ will gain
150 BTU/hr/sq ft. 1250
 $\times 150$
187500 BTU gain/hr
from Sun

2) Body heat gain ~~100 BTU~~
generating 500 BTU/hr/person =
50,000 BTU gain per hr

3) Conduction Loss -
 $Q = A \Delta T U$
 $Q = (3500)(20)(1.2) = 85,000$ BTU/hr
Loss from conduction

~~xxx~~
~~xx~~
187,500 + ~~50,000~~ - 85,000 = 150,000
Total Gain per hour.

~~xxxxxx~~

4) Heat Loss Due to Passing Air Through

~~xxxxxx~~

$$150,000 = (W)(.016)(20)$$

$W = 480,000$ cubic ft per hour

480,000

$$\frac{480,000}{60} = W \text{ expressed in CFM}$$

$W = 8,000$ CFM

5)

$$30 = V$$

$$V = \frac{\left(\frac{\text{CFM}}{\text{sq ft opening}} \right)}{60}$$

or

~~xxx~~ opening = 4.5 sq ft.

Rough guess your door openings ~~xxxxxxx~~ a bit ~~xxxxxxx~~ smaller to allow for ~~xxx~~ (inevitable) tears which will increase the area of air leakage.

Two medium-size fans (around 5000 CFM) might be a good solution, providing good control over the ~~xxxxxxx~~ air-flow as well as a double blower system

ANCHORING

ANCHORING

If your inflatable is going to be up outdoors in any wind, it will need an anchoring system. For small volume (500 sq.ft. of floor area or less) interior weights should work; these could be sand bags or water bags. Larger structures require heavier anchoring. There are a number of ways of doing it: integrally made tie downs, buried edge, weighted edges, taped edge, or tension net anchors. Buried edge is good for a semi-permanent installation where you can dig a trench. A taped edge is good for a small installation on a smooth floor; tie downs and tension nets are good for sites with existing things to tie to (trees, fire hydrants), or where it would be easy to drive tent stakes or augers.

The anchoring system must withstand not only windloading but also the internal air pressure of the structure. Precise structural calculations should be left to 2 engineers, 3 Ph.D. mathematicians, and a computer, but a little rough math can give you a close enough estimate of what anchors to use. We will deal first with inflation pressure and second with wind loads.

PRESSURE LOAD . . . On any surface that is curved in one direction, i.e., a cylinder or a long pillow, the tension per unit of width is equal to the internal pressure multiplied by the radius of curvature. Work in pounds and feet. Some ball-park figures on figuring pressure: the highest pressure you are likely to get with a powerful direct drive fan is 2 pounds per sq. ft. (2lb./sq.ft.). A normal working pressure is 1lb./sq.ft. On a water monometer, 1" of water equals 5lb./sq.ft. (see monometer drawing). Indoors you can keep a structure up with as little as 1/4lb./sq.ft.

Make a sketch of the shape, find the radius of curvature by making a section through it, on this diagram the tension equals pressure times radius of curvature. The tension is the downward force you need per foot of edge.

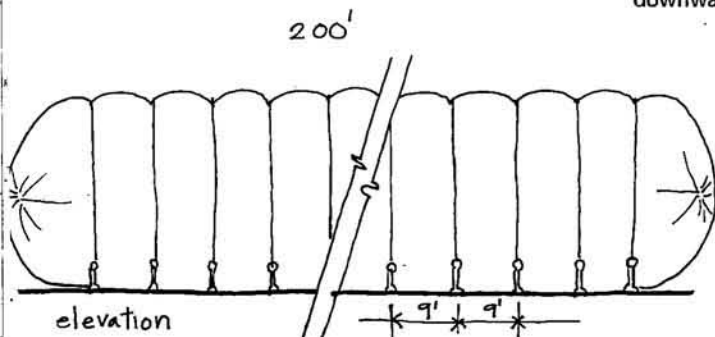
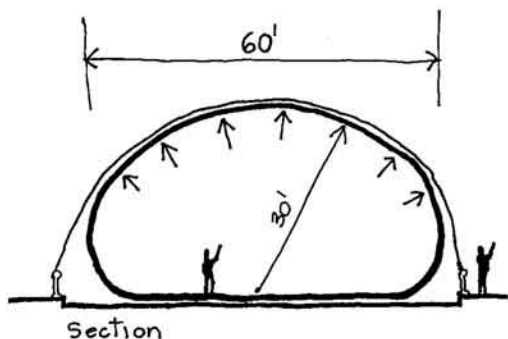

$$T/ft = (P)(R_c)$$

T/ft = downward force needed per foot of edge

P = pressure (in lbs./sq.ft.)

R_c = radius of curvature (in feet)

EXAMPLE: The Earth Day Bubble by Charley Tilford in New York City was 200' X 60', radius of curvature was 30'. The anchors were parking meters spaced at 9' along the long edges (the 200' dimension). The pressure which the bubble was designed to withstand was 2lb./sq.ft. The ropes spanned between parking meters so the load on each rope was (tension per foot of width) times (spacing between meters). Tension = (30')(2lb./sq.ft.) and Tension per rope = (9')(30')(2lb./sq.ft.) = 540 lbs. per rope. 2500 lbs test 3/8 inch dia nylon rope was used.

If you want to do an inflatable with the weighted edge (instead of a plastic floor): find the total downward force required, then divide by the perimeter to get force required per unit of length of the perimeter.

WINDLOADING

To figure windloads: find the area of resistance the structure presents to the wind. (length)(height). The horizontal force from the wind blowing on the structure can be up to 10lb./sq.ft. depending on the shape of the structure and the wind velocity. A lower, more shallow-sloping profile will create less resistance (and will ~~even~~ create *more* negative pressure on the leeward side of the bubble.

Bubble I presents a large area to the wind. The negative pressure is concentrated on the back side. (This negative pressure is created the same way as lift is created by an airplane wing.) Bubbles II and III are actually getting some lift help from the wind. Bubble III would probably need less fan pressure in the wind because of the negative pressure on the outside created by the wind blowing over the low profile. A structure to be left up for more than, say, an afternoon (or a structure for an event which you don't want to have to postpone due to high wind) should be designed for 10lb./sq.ft. pressure. For a structure 50' long and 15' high, the design force would be (50')(15')(10lb./sq.ft.) which is 7500 lbs force on the structure.

$$\text{FORMULA } (\text{area presented to the wind})(10\text{lb./sq.ft.}) = \text{wind load}$$

If 7500 lbs seems like a lot, think of the force on just the minimal area your body presents to the wind in a good, high wind.

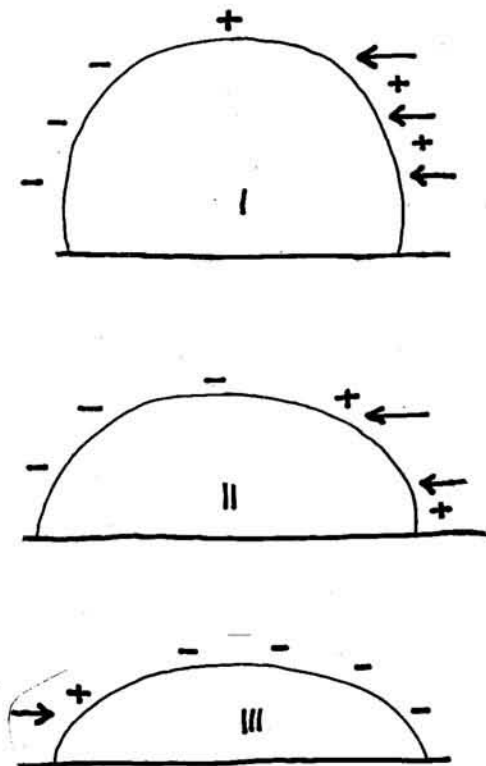

TOTAL LOAD

This windload must be added to the inflation load to get the total load that the anchoring system has to counteract. If it is possible that the whole wind-load could be on one anchor point (such as when a square pillow with a square net anchored down at each corner presents one corner to the wind), then the total windload must be added to the inflation load on each anchor. If the wind is coming directly against one side, then the windload divided by the number of anchors that will be under tension should be added to the inflation load for each anchor.

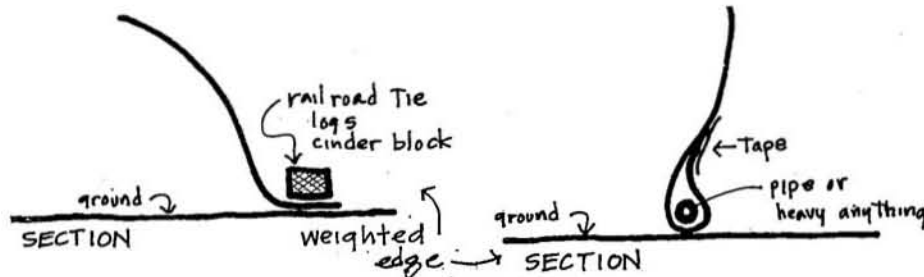

TYPES OF ANCHORING SYSTEMS

These systems have the structural advantage of distributing the forces evenly around the whole perimeter of the building. We used one with pieces of pipe taped into the edge over a waterbed environment so that we were able to remove the inflatable by lifting it over the bed without having to move the water bed which weighed 3000 lbs. Because the plastic floor is eliminated, this type of inflatable would also be good for a greenhouse, storage facility, pool cover, etc. These types might tend to last longer, too, because they are more static so people probably wouldn't walk through the walls or otherwise freak out at the expense of the plastic.

WEIGHTED EDGE

Weighted Edge is anything heavy that can be laid on the edge of the plastic or taped into the edge. See illustration.

I saw an interesting inflatable that John Reeves did in the Summer Thing program in Boston that was an inflated hemisphere (out of 2 mil silver mylar) that tied down to a piece of telephone cable that he had gotten the phone company to donate. A 20' diameter circle of this phone cable weighed about 200 lbs. The phone company usually just chops it up and melts it down again. John's bubble leaked air between the cable and the edge of the plastic. This could be desirable if you want to circulate a lot of air, but if you have pressure problems a flap could be taped on inside the bubble, like on giant Bird-Air and most commercial inflatables. A section of the detail might look like this:★

Looking at the elevation drawing of this, notice the catenary curves between each tie-down point. This is the natural configuration the line between two weighted points on an inflatable takes, so it will strengthen your bubble to actually cut a curve to an approximate shape, reinforce the edge by taping a piece of cord into the edge and running the tie-down loops through the string. This will distribute the force of the tie-downs through the whole edge of the inflatable, rather than gathering the stress at the point where the tie-down meets the edge of the plastic. This will minimize wrinkles and tears due to concentrated stress. Inflatables that are to be tied to stakes can be made in the same way as this.

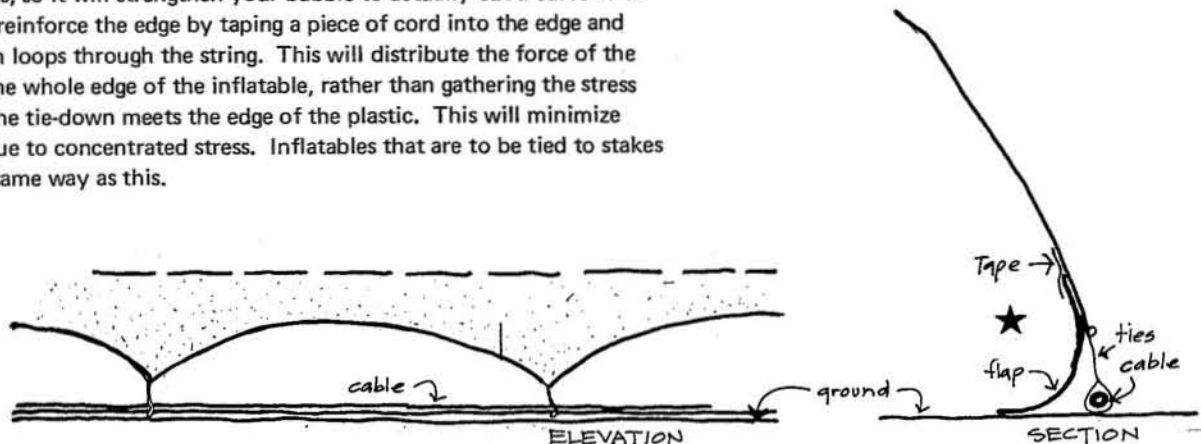

ANCHORING

TAPED EDGE

Edges can be taped to anything smooth enough to tape to

BURIED EDGE

Jim Cook at H. T. McGill Co. in Houston showed us this method of burying edges. He has had extensive experience with it. His company has done polyethylene swimming pool covers, Christmas tree warehouses, and other stuff. The holes in the bottom are important. Unless they are there, the underground poly collects water, makes mud, and the lubricated plastic slips out of the ground.

FRAME EDGE

Jim Cook also showed us pictures of a system he did with two by four frames. Wrap the poly at least one time all the way around the smaller piece of wood before nailing or bolting this on to the 2X4. The frame will act as tension ring containing the inflation pressure, as well as acting as a hold-down against the wind.

TAPED ROPES

This is one of the few ways to make a poly bubble that has a plastic floor without a net. Another way is just to put some heavy things like people or bricks wrapped in something soft inside the bubble while inflating it.



THE 60' VINYL PILLOW vinyl requires fewer, wider spaced cords in the net because the material is stronger. This net is of 10,000 lb. strapping held by 10,000 lb. abgurs.

PHOTO BY SUSIE MILLER

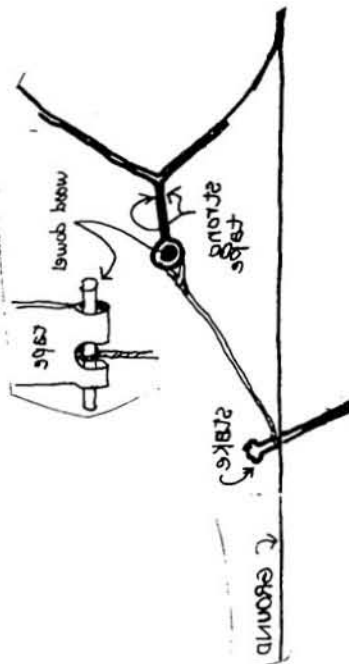
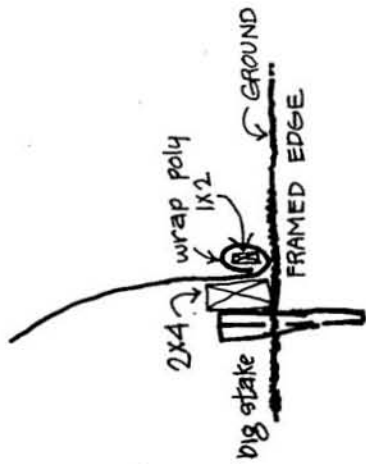
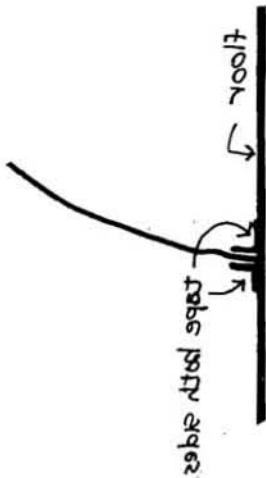

NETS

Advantages of a plastic-floor building with a net are portability, total enclosure, large inflatables, and ease of construction of the anchoring system. In a large inflatable, it would be difficult to make a connection between a tie-down rope and polyethylene that could withstand the great forces on the bubble. Nets can also be very beautiful.

To design your net, make a model of your bubble and start playing with string. If you can, set up the model somewhere that you can nail into the floor (like a piece of plywood) to simulate anchoring points. If you already have a site for the bubble picked out, put nails in where there are natural anchors, like parking meters or trees or cars. If you are going to use your own augers, then you are totally free to do anything with the net, spider webs, star shapes, giant grids, whatever. . . . To test your model, get the fan that is going to hold up your big bubble and use it as a wind source. This testing can be really informative if you vary the wind and the pressure inside the inflatable. Nylon string (hardware store) is a nice model material.

Building a net can be a major job. We made a 100' X 100' net with a 5-foot grid by staking down all the horizontal ropes, then tying slip knots every 5 feet in each rope, slipping the vertical ropes through and popping the knots.

The knots at the edge of the net were just square knots, tied onto loops in the edge rope. If you are tying knots, think about knots that don't involve slipping the whole rope through each knot.

The 100' pillow net: Our first net was this 100' square. We used parachute cord for the bulk of the net, 1/4" nylon rope for the 2nd, 3rd, and 4th ropes from the edge, and 3/8" nylon rope for the edge. At each corner we tied a "D" ring to avoid the rope rubbing and cutting itself at this stress point. From the D ring to the anchor we used some 10,000 lb. nylon strapping that we got from a surplus store with a double D ring on the end so that we could tighten and loosen the net. Tightening the net in the wind helped quite a bit in lowering the profile of the surface presented to the wind. We used 10,000 lb. augers. Charley Tilford has since made another 100' pillow out of 6 mil poly (the original was 4 mil) using a net with 20' squares instead of 5' squares.

ROPE STRENGTH

Charley sends from New York the accompanying approximate rope strength chart:

DIAMETER	BREAKING POINT	NYLON
Parachute	550 #	800 #
3/16"	1000 #	1300 #
1/4"	1800 #	1900 #
5/16"	2800 #	2750 #
3/8"	4000 #	4200 #
1/2"	7000 #	

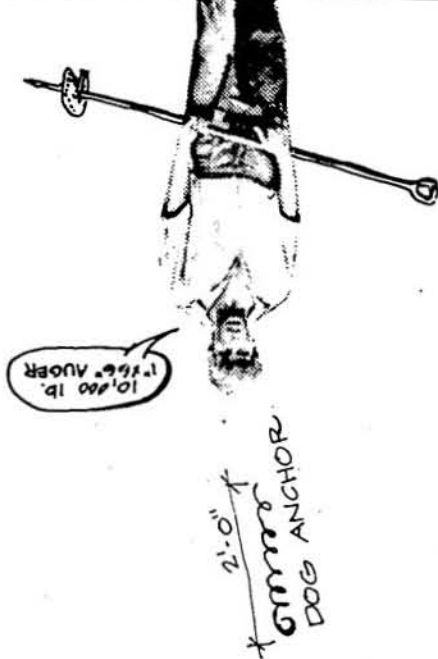

ANCHORS

We got our 10,000 lb. augers from a telephone supply co. in Houston. Telephone supply co.'s are generally a good source for these. These augers are about 5 feet tall. A.B. Chance Co., Jersey Ave., New Brunswick, N.J. has 10,000 lb (1" X 66" shaft, 8" helix) augers for about \$6.15. Big augers generally have an eye at the top that you stick a long (6') heavy pipe through and twist them into the ground. This generally takes 2 people. Small bubbles can be anchored with dog-anchors which cost about \$1.25 each from a pet store or hardware store. Trees, light poles, fire hydrants, parking meters, cars, etc., are still the cheapest.

When you have your bubble up and the wind comes up, tighten your net and increase your inflation pressure. The increased air pressure will keep the side of the bubble from caving in and the tightened net will decrease the area presented to the wind. (See photo of bubble about to take us all for a ride in Air Supply Section.) ★

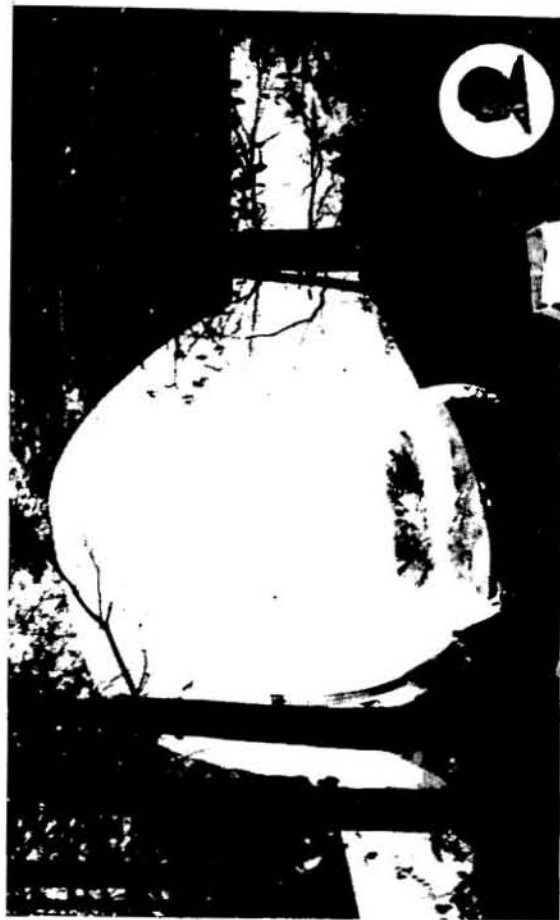

ENVIROMINTS

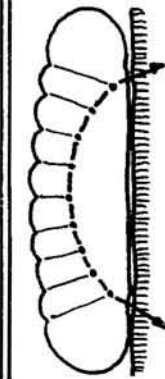

MONKEY POD

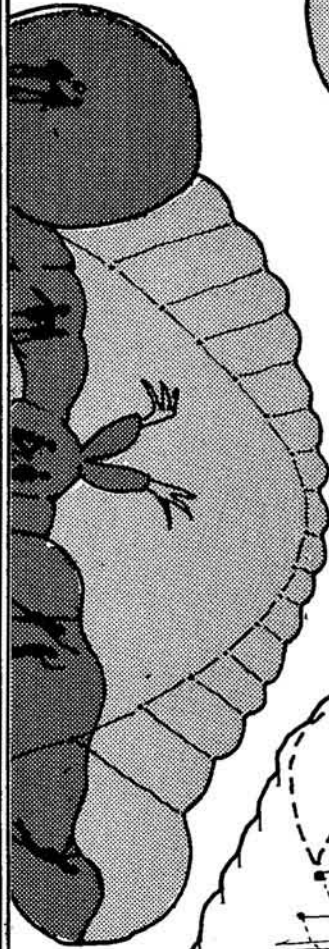

SHAPED BY NETS

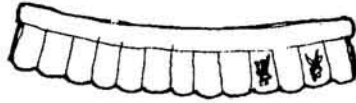
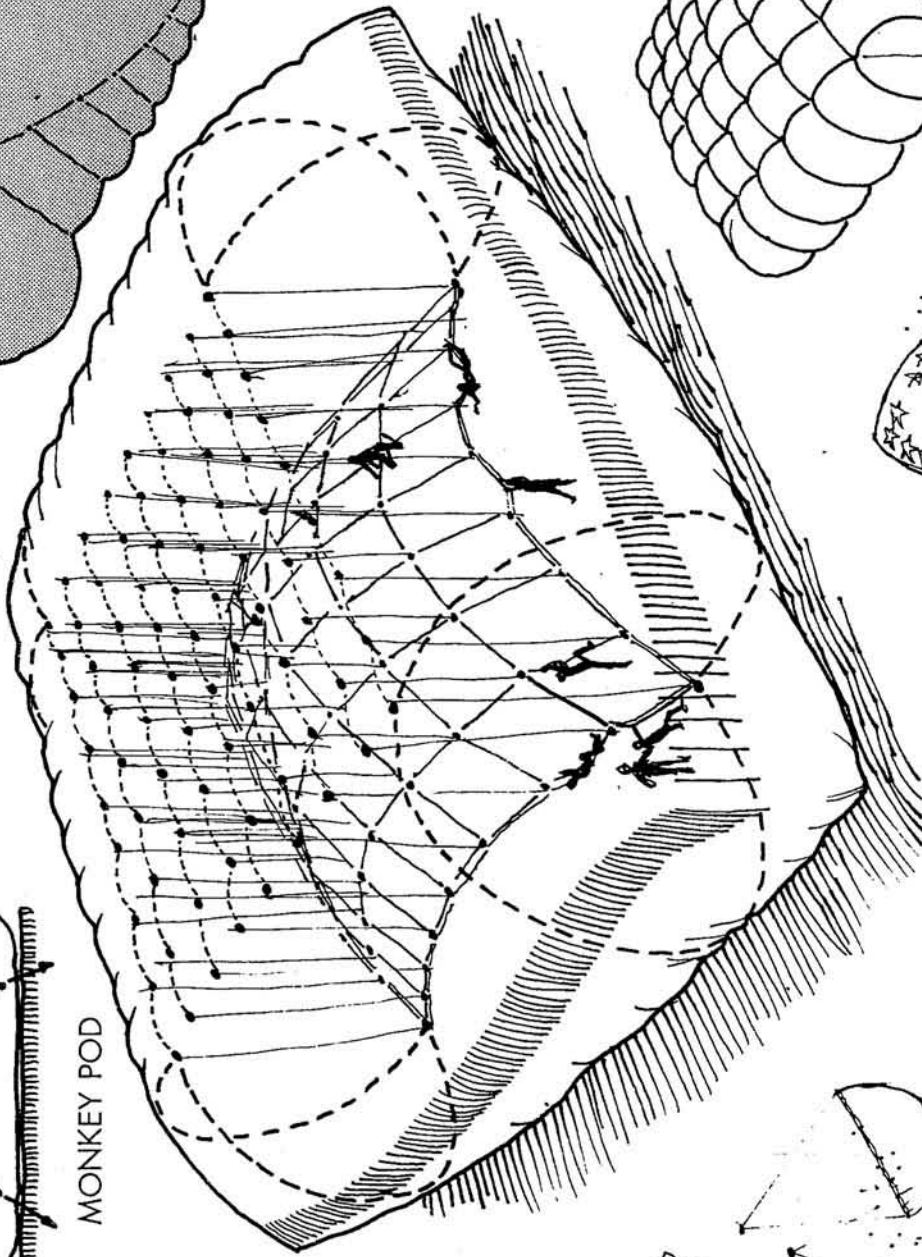

HIGH PRESSURE RUPPY RING

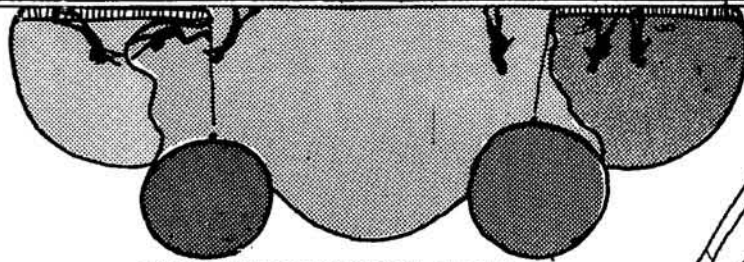

PRESSURE VARIES WITH USE

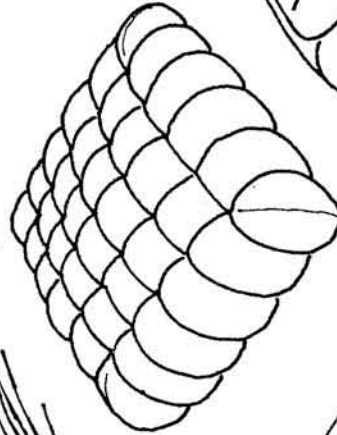

LOW PRESSURE UNDULATING

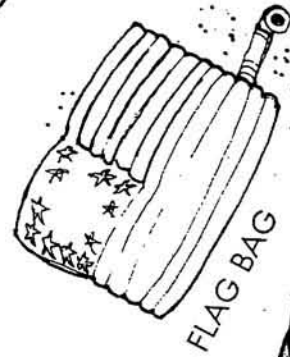

FLAG BAG

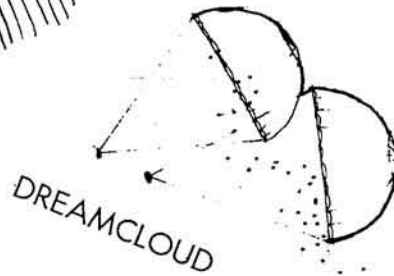

DREAMCLOUD

LOW PRESSURE



RAINBOW ORCHARD

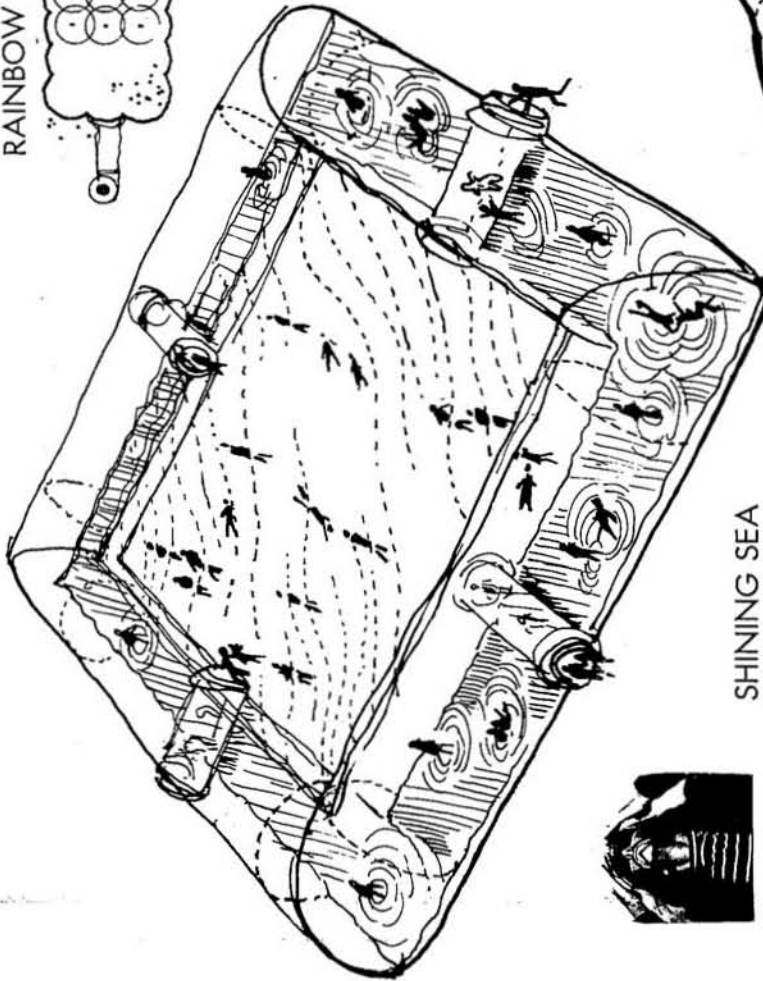
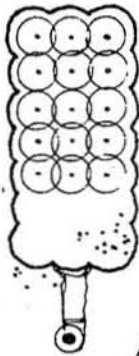

SHAPED BY NETS

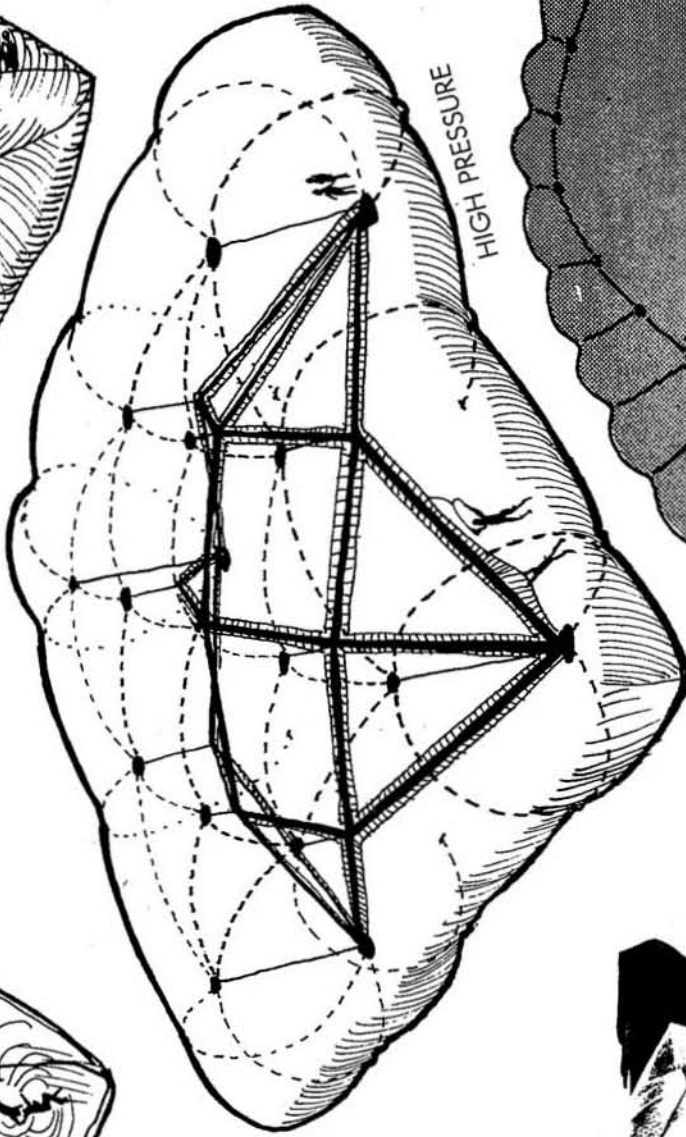

HIGH PRESSURE

PINK ORIFICE

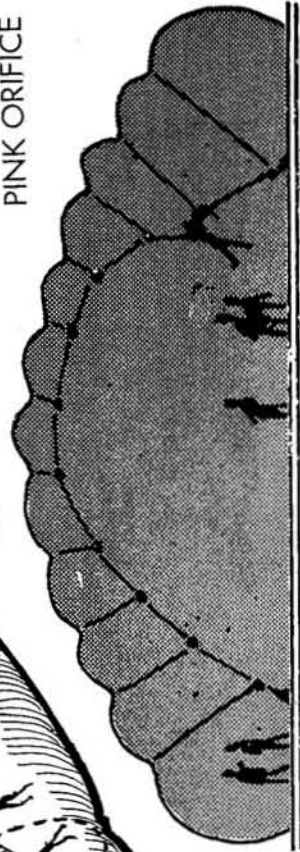

SHINING SEA

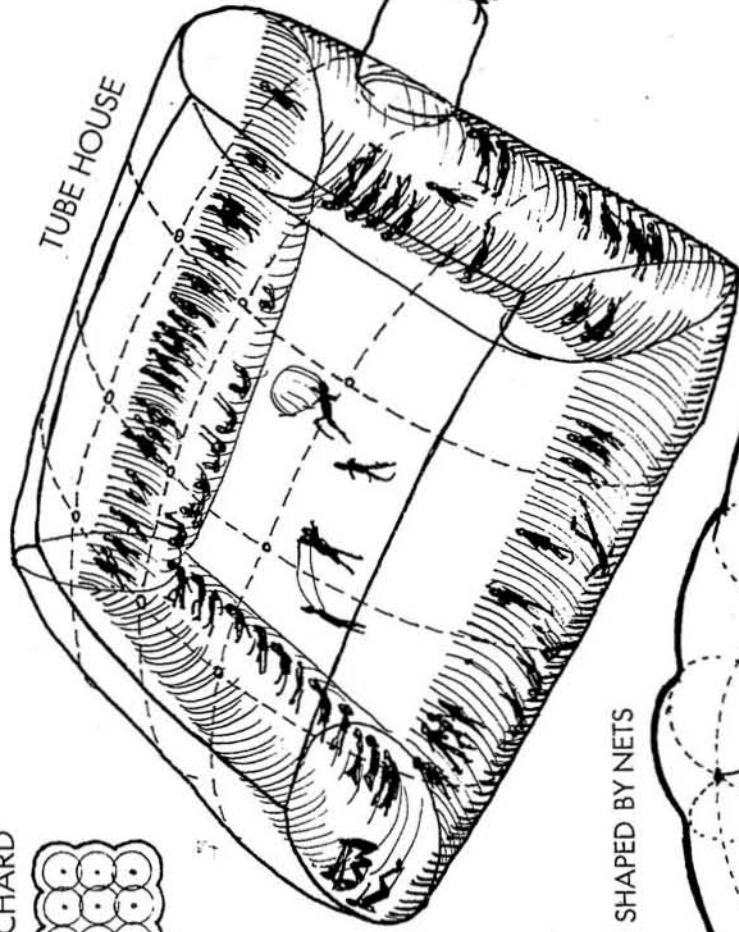
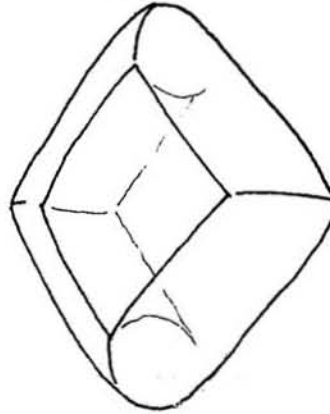

TUBE HOUSE

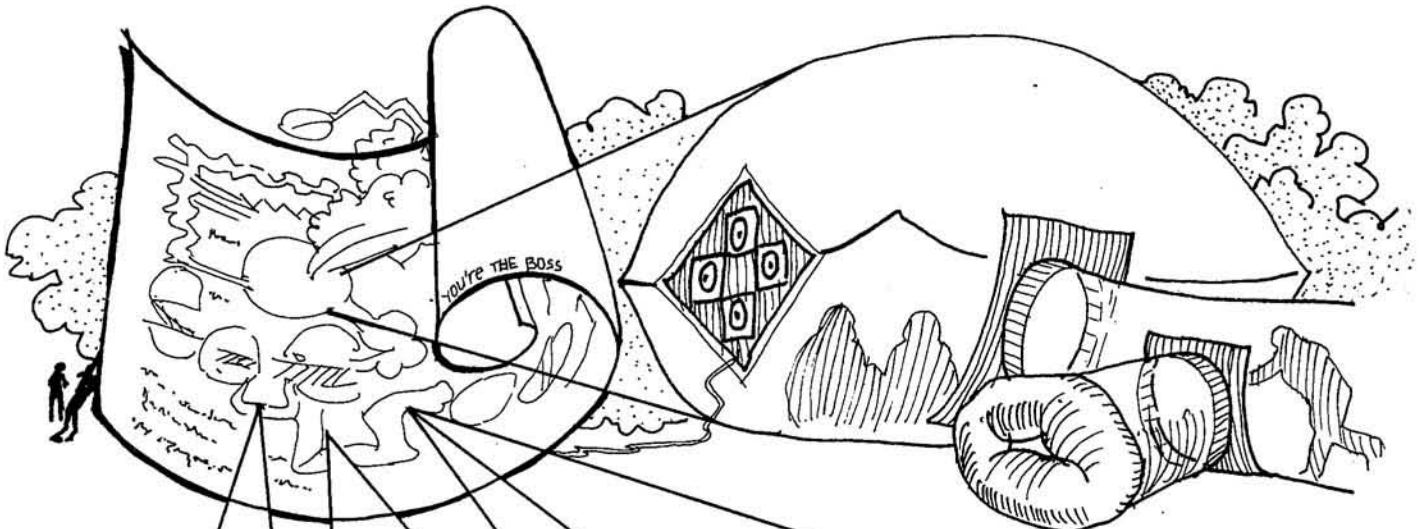

With these new Ant Farm Components you now can realize your fantasies with most of the dirty work done already. Complex curves, tube joints, fan tunnels etc. can be made ahead of time, ready to be inserted into the structure at your command. All pieces are made of high-strength vinyl, completely flexible (shown here stiffened as if inflated)

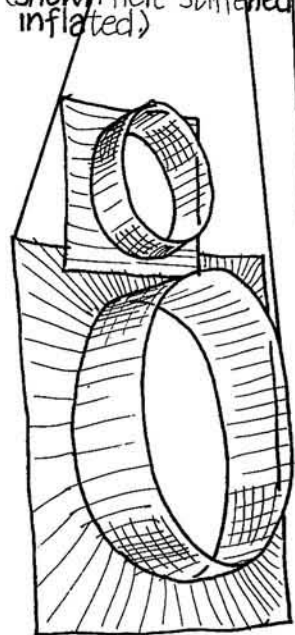

Flat (nearly flat) Tees.

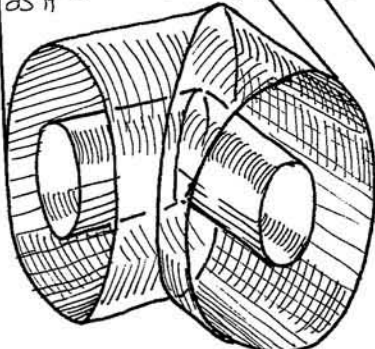

45° Angles

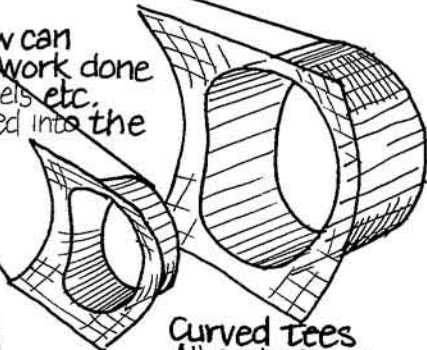

Curved Tees
All combinations



Rigi-Flex
Fan Tunnels



Power Blanket
4-Fan Patch

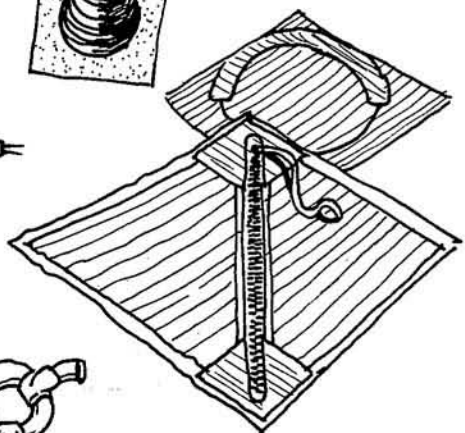

Zipper Hatchways
Access Panels

Idea Plumbing

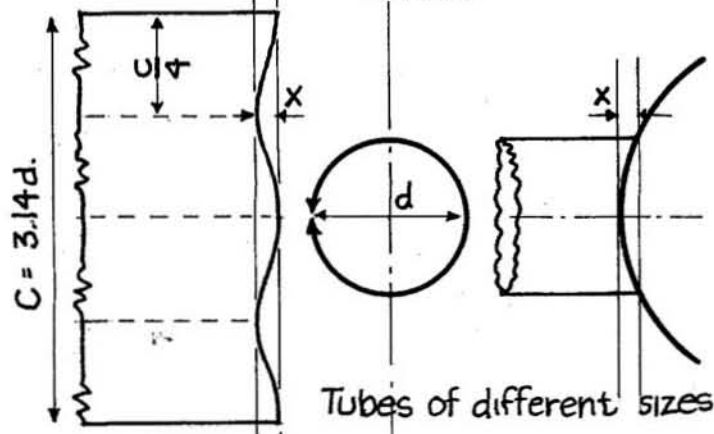
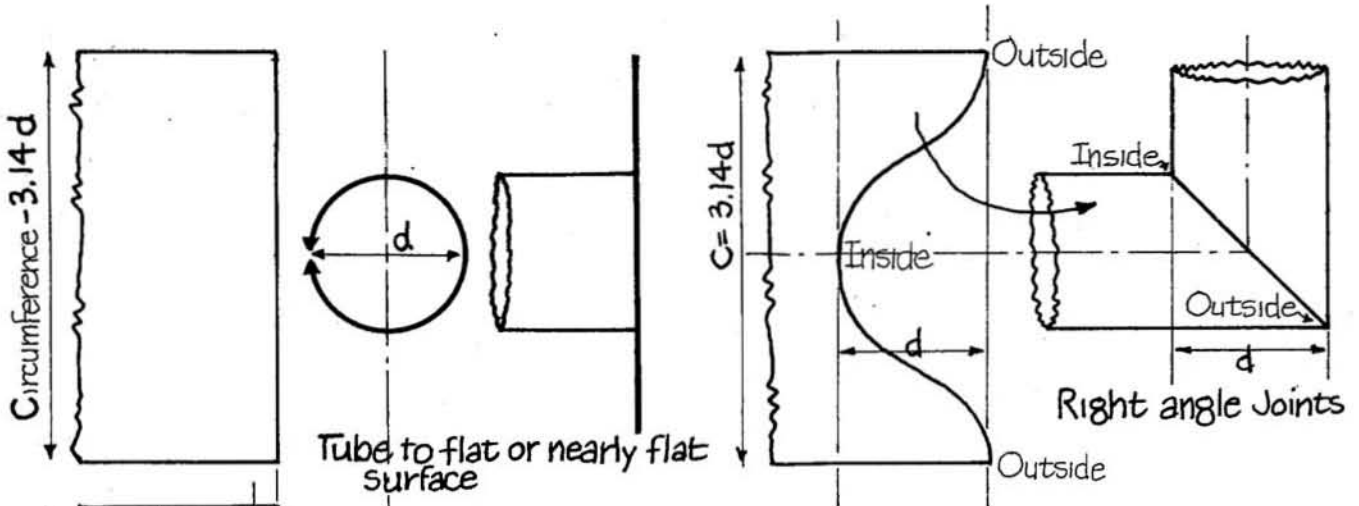

TUNNEL JOINTS

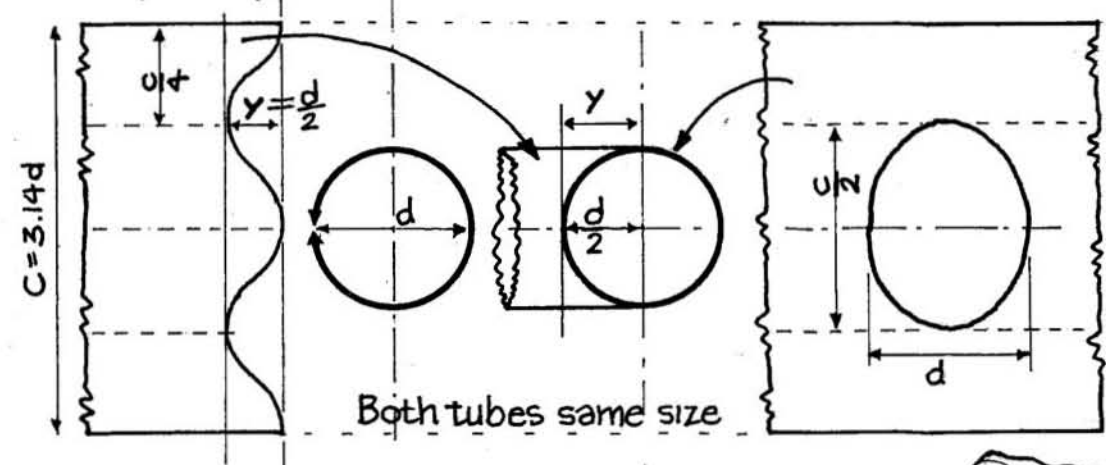

Plan ahead so that the most complex tunnels can be fitted before the major pillows are taped up.

Make up a few joints ahead of time with care



They can easily be taped into straight lengths of plastic during the mad rush of

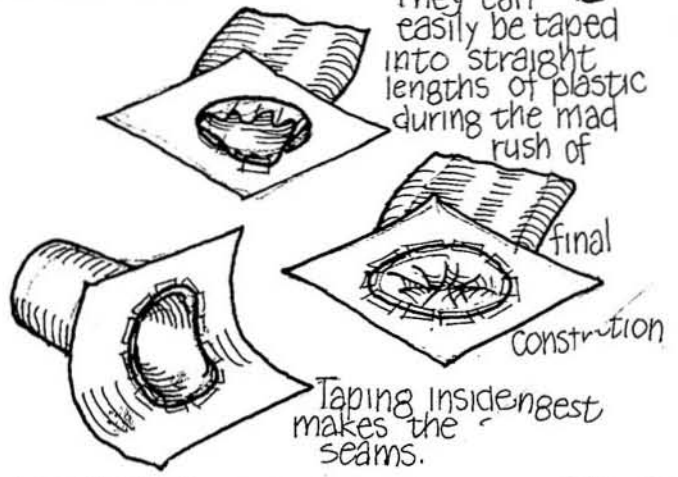

To find out how to do this one, just take apart an old pair of pants

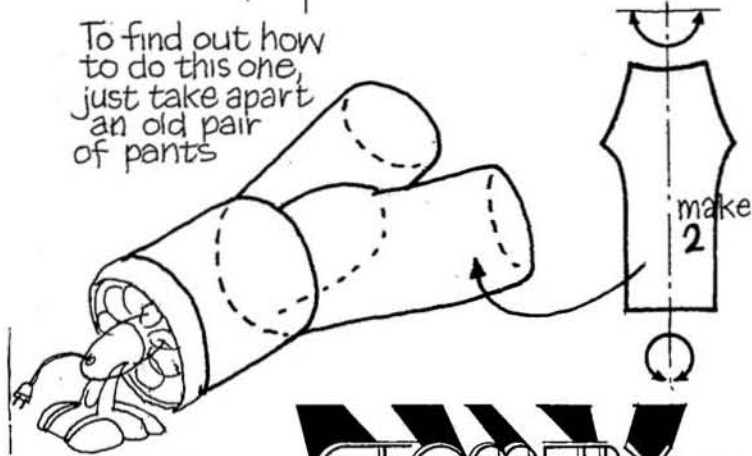

Wrinkles in your pillow mean the plastic skin is stressed along the wrinkles
 There are little or no stresses the other way.

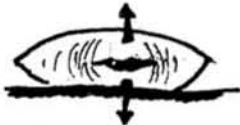
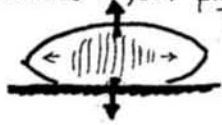

A slit cut across the wrinkles will tend to spread open and leak air.
 Not recommended

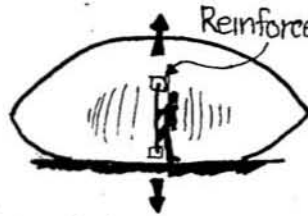

A slit cut along a wrinkles will be a self-closing entrance.

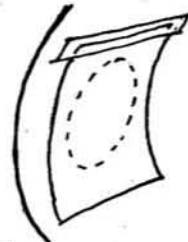
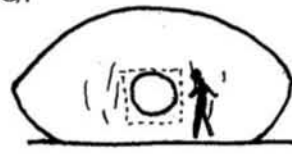

A flap taped behind a circular or ovoid hole (No larger than crawl-through size) will automatically close due to the air pressure inside

ENTRY



A ring or hula hoop taped around a circular hole will become a self closing door if it is located so it rests flat on the ground when no one is entering.

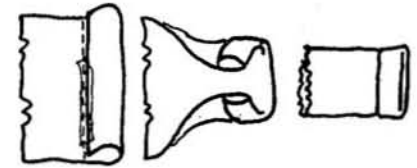
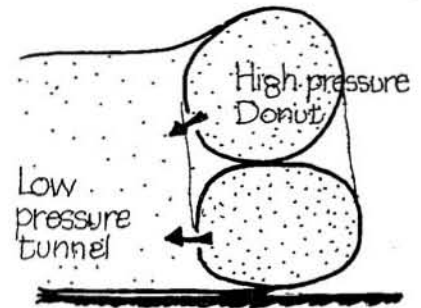
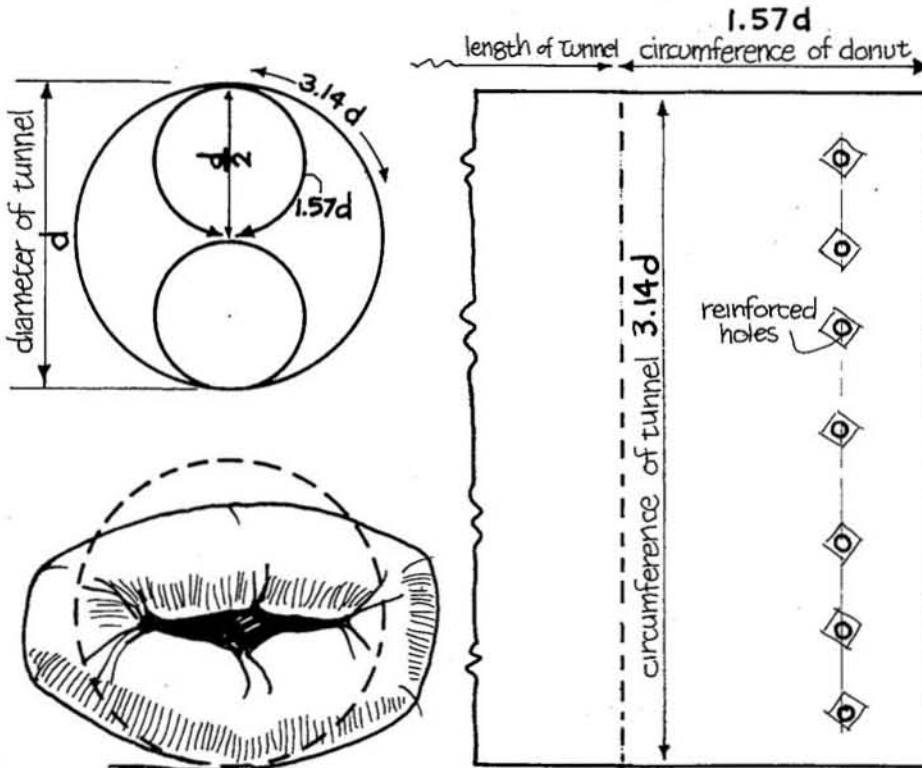

Hot Lips - a floppy donut at the end of a low pressure tunnel. When connected to the blower, small holes admit air to the tunnel from the lips, thereby inflating it

BLOWER

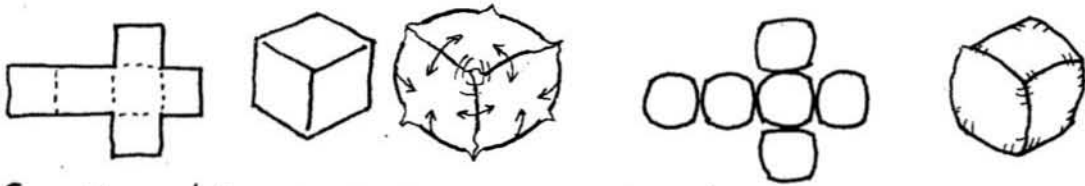

Curvature determines stress: a tiny plastic hose carries a hundred pounds pressure and a huge weather balloon has a pressure barely above atmospheric. Yet the stresses on both the hose wall and the balloon skin may be the same - the tiny tube wall is sharply curved and the weather balloon surface is flatter. If the earth were a giant balloon, imagine how little pressure would be needed inside to tense the horizon so tight!

Make a little cube out of thin plastic sheet. Then inflate. The corners, sharply curved, hang limply, while the midpoints are taut enough to burst! Being flatter, these areas take more stress. The cube tries to become a sphere - a shape in which the skin curves to an equal amount in all directions. Clearly, the best shape is a sphere, and these pages are devoted to getting as close to spherical as possible with flat materials.

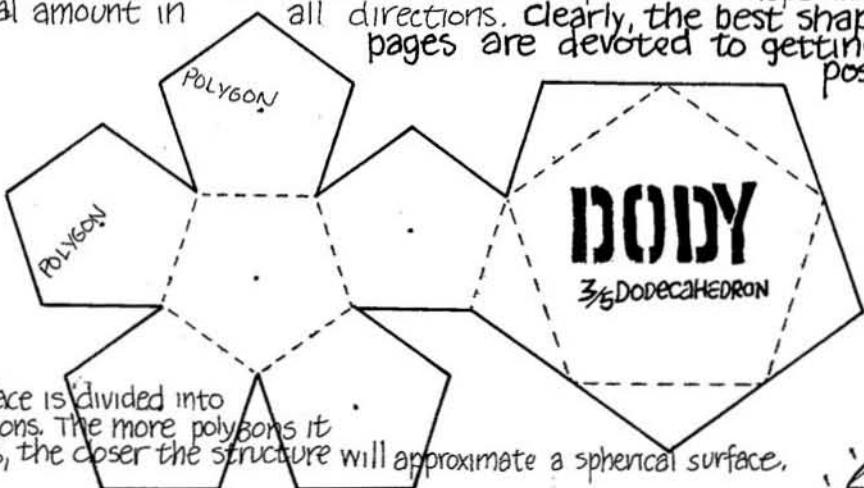

Surface is divided into polygons. The more polygons it takes, the closer the structure will approximate a spherical surface.

POLYGON METHOD

Get ideas from: baseballs, volleyballs, soccer balls, geodesic domery, zorries, geometry books

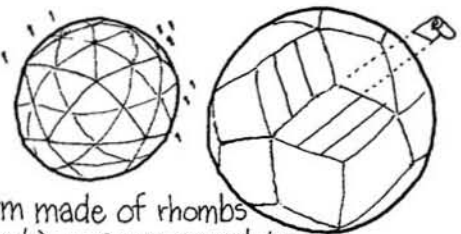

A form made of rhombs (diamonds) is economical to make from rolls of plastic.

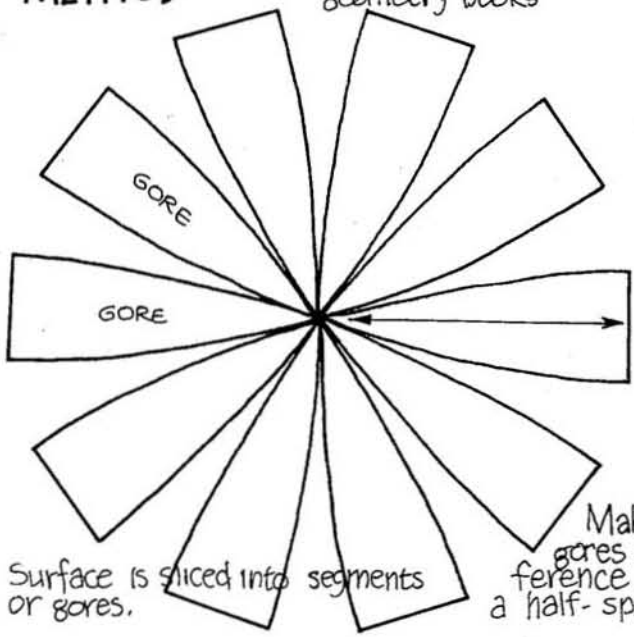

Surface is sliced into segments or gores.



Making the length of the gores equal $\frac{1}{4}$ the circumference of the base gives a half-spherical shape.

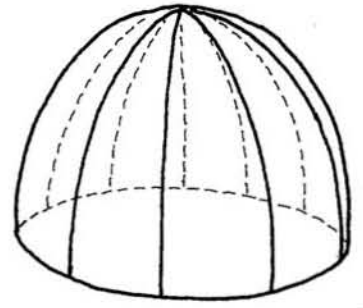

GORE METHOD

Get ideas from: peeling tangerines, weather balloons, inner tubes, beach balls, inflatable warehouses, gloves, world globes.

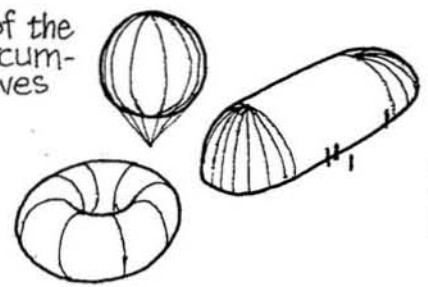

GEOMETRY

Make up this star figure. It is based on equilateral triangles

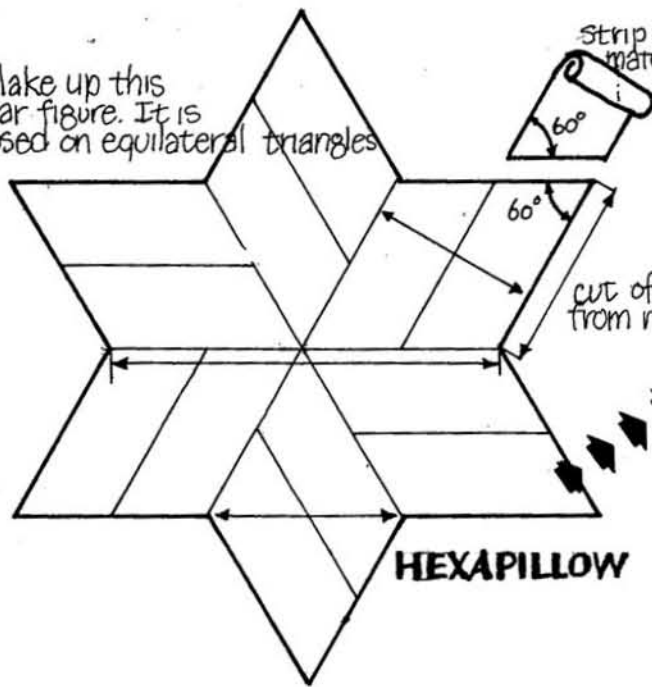

Fold the points over to the center

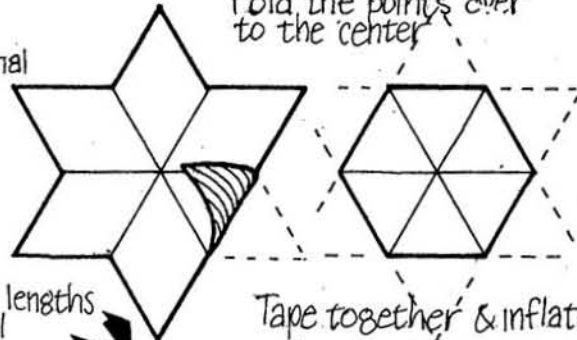

Tape together & inflate

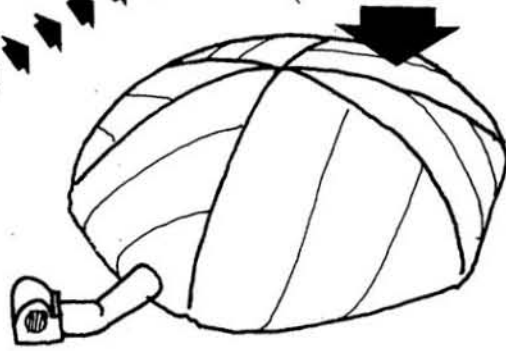

Make up 2 star figures (above) only difference being not taping the center seams $\frac{1}{2}$ way in (or $\frac{2}{3}$ way)

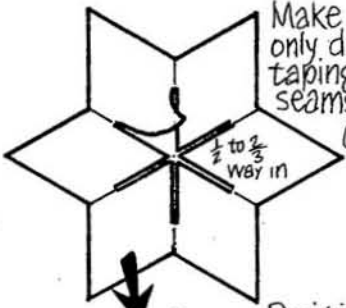

Position one star above another as shown. Fold top flaps back.

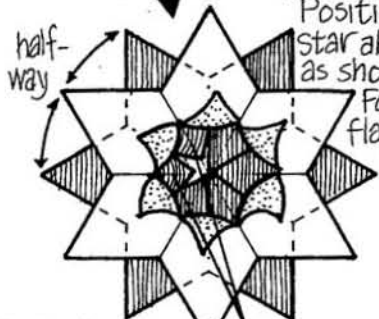

Pull 2 bottom flaps up & lay back. The top flap just above gets taped in between these two

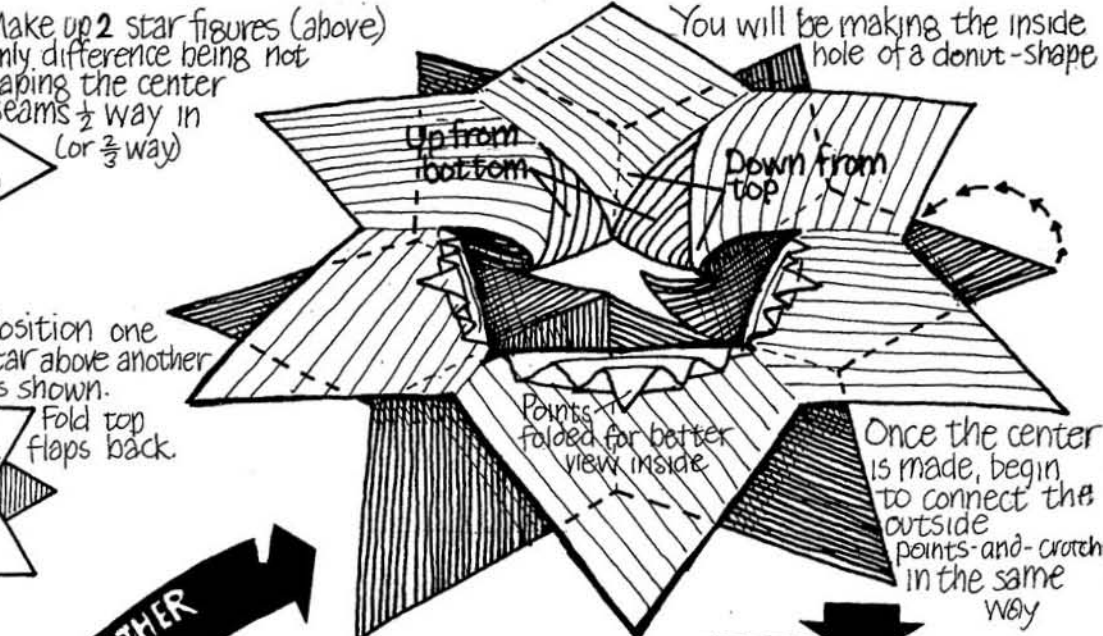
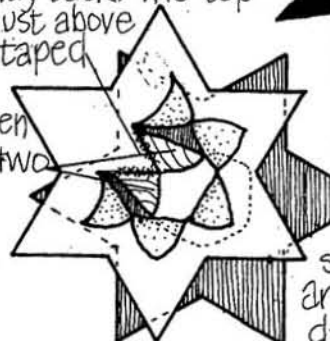

ANOTHER SPARE TIRE

Continue around, sliding the stars around for the best position to work from. Taping is difficult: the limp structure will not lie flat, and the process is hard to depict.

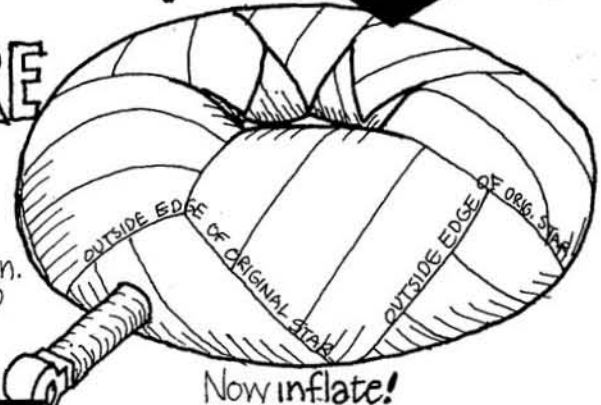

BURIED EDGE *inflatable*



HERES HOW - USE 6 MIL POLY COMES IN 20' WIDE ROLLS FIGURE THE SIZE IN 20' MODULES

★ DIG A TRENCH 24" DEEP 12" WIDE

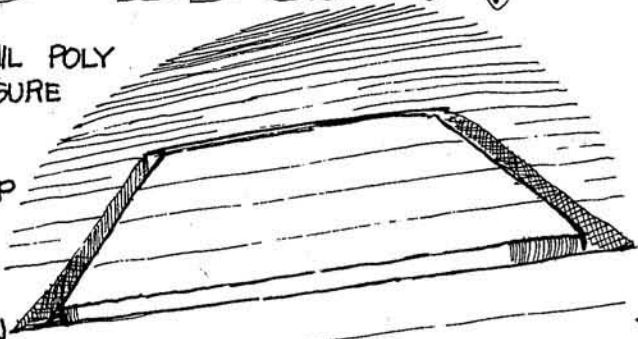

★ CUT POLY - SEE PATTERN DIAGRAM - NOTE 40% CUT AT CORNER ALLOWS FOR INTERIOR HT. CUT DRAIN HOLES IN TRENCH EDGE

★ BURY EDGES IN TRENCH ADD ROCKS FOR WEIGHT - BUT AVOID SHARP ROCKS WHICH MAY CUT POLY. - ADD DIRT, PACK DOWN

★ FANS - ABOUT 1000 CFM USUALLY AN ATTIC FAN OR OFFICE FAN WILL DO
USE EITHER FAN DETAIL

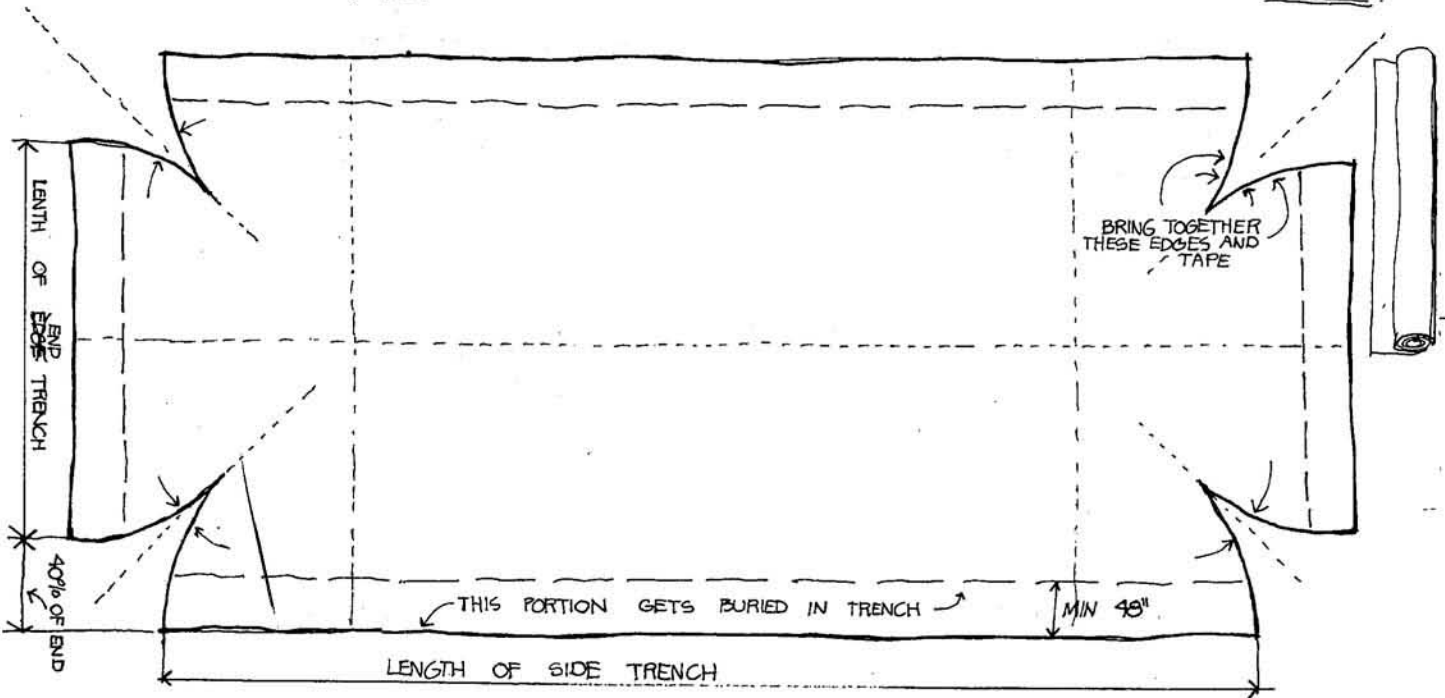
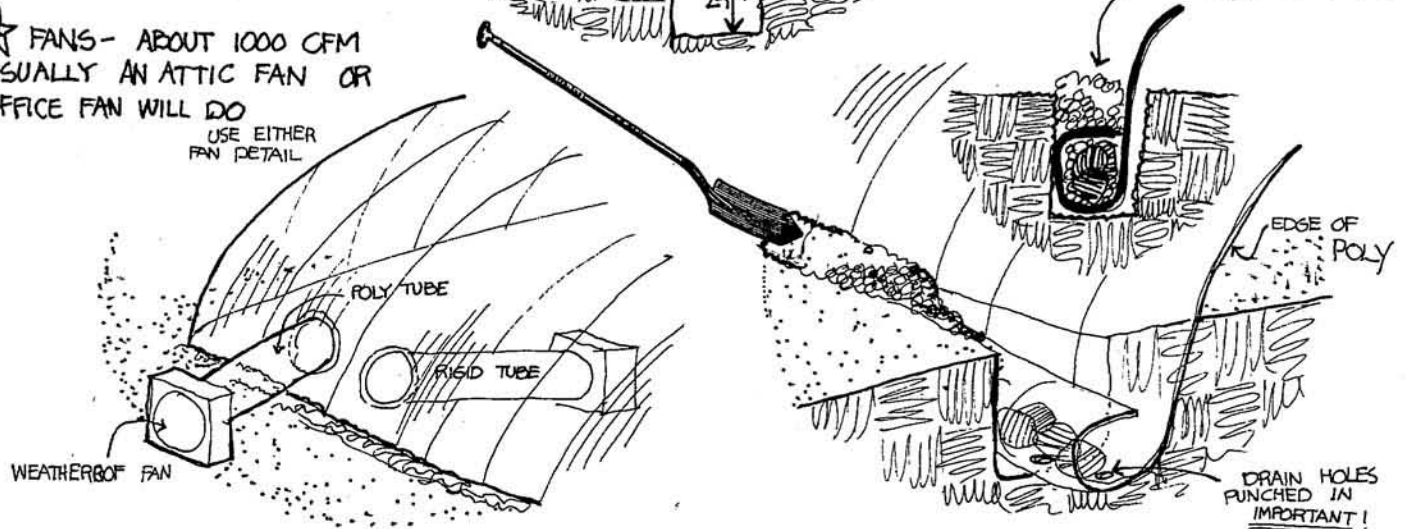

PNEUMATICS - A KEY TO VARIABLE HYBRID STRUCTURING

After seeing Mr. Bird's impressive achievements and hearing Mr. Lundy's enthusiasm I wish to introduce a note of constructive pessimism. Pessimistically, I consider that the application - in the field of structures - of pneumatic techniques is too involved with solving normal structural and shelter problems. While the intermittent enclosure of swimming pools or protection of traditional construction work is extremely useful, such applications, if too widespread, can well result in the following actions which are detrimental to increasing the development of ▽

pneumatic technology:

- 1) Over-emphasis may be given to the static siting of air structures.
- 2) Direct cost comparisons with traditional structures may be made.
- 3) The fixed-period accommodation available with air structures may only be exploited for disaster or random-use of air structures.

All these actions can retard the investigation of new applications requiring improved and more complex air-structures. In addition the development of new materials and fabrication techniques should be related to new applications rather than concentrate on the perfection of existing applications since these very applications are still extremely arbitrary.

While space exploration and defence programs provide a valuable technical "spin-off" of the development air-structure technology, its very peculiarity is likely to restrict, in the near future, the technological advance of air structuring related to civil and social activities. Too many architects and designers wait to see what NASA and various Defence projects will produce. This conference must increase the content and frequency of exchange between scientists, engineers, manufacturers, architects, planners and social administrators. An immediate task could be to agree on the semantic definition of the various structures and systems we are now discussing (air-supported structures; air-inflated structures; air structures; pneumatic membrane structures; sealed pneumatic structures).

In this paper, reference to air structures includes air-supported and air-inflated structures, together with air-controlled and air-moved structures. In addition, we must keep mutually aware of the alteration of attitudes of authorities and others to the employment of air structures. In September 1965 the Department of Architecture and Civic Design of the Greater London Council refused to license a high-pressure air-beam structure for temporary use as a place of public entertainment on the grounds that it constituted merely "a tent without poles or frame". In December 1965 the same department of the G L C were prepared to consider the use of the identical structure on receipt of calculations related to stability. Only when a continuous exchange is estab-

lished can individual groups - in my case architects and physical planners - make accurate and substantiated demands on pneumatic technology. At this stage of the conference I list some aspects of this technology which are of particular interest to me as an architect:

- a) Multi-membrane construction which enables variable pressurisation and containment (cf. paper by R. Szilard).
- b) The availability and performance specification of transparent membranes.
- c) The control of light and radiation by both membranes, intermembrane construction and contained gases or liquids (cf. papers by R. Szilard and N. Laing). ▽
- d) The containment of granular substances between membranes to control humidity, sound transference etc.
- e) The capacity of controlled air movement through the material of the membranes. Such a possibility enables changes in the normal methods of foul air evacuation.
- f) Multi-layer bonding enabling variable cell construction. Such hybrid construction can enable the simultaneous use of high pressure sealed volumes and low pressure air-supported volumes.
- g) Ultra-sonic bonding enabling an increased variation of membrane material. An increased use of various materials is urgently required not only to enable varying structural performance specifications to be met but also to achieve varying textural qualities.
- h) Further information on the performance of high and low pressure structures in movement. The existing U K inflatable vehicle transporter which both protects the vehicle and propels it on the Hovercraft principle is an example of this. Movement must include the employment of the Hovercraft or Ground Effect Machine (G E M) principle.
- i) Self-packing, on deflation, of large volume membranes.
- j) A new method of costing air-structures which is related to the variation of use and not merely material and unit plant cost. Any mechanical plant, pumps, blower etc. must be accepted as a structural element.

The variation and individual control of volumes singly or in combination enables the separation of membranes related to the elimination of particular adverse conditions (cf. paper by R. Szilard).

As roofs, walls and floors no longer exist in the conventional sense, their pneumatic equivalents no longer need to provide the additive structural support normally required. Only collective stability is required and the air one breathes can become the major structural force. This being so, the interior fittings or divisions of such structures become relatively more permanent (see the interior of Lundy/Bird US Atomic Energy Commission's travelling exhibit).

Movement of such internal parts must also be investigated. The use of air-pallets for such intermittent movement is extremely valid. The use of an air-conditioning plant as the structural pressure feed is only one

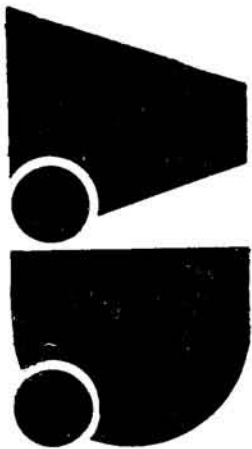

67	72	D5		
----	----	----	--	--

Paper given at 1st International Colloquium
on Pneumatic Structures Stuttgart

example of the advantage of co-ordinated use of air within such structures. Methods of cleaning and movement related to the whole or part of the structure should also be included.

In the past major urban congregation areas were determined by the location of a large permanent structure providing mass accommodation or shelter such as the Roman Circus, the Mediaeval Cathedral, the Market Hall and the Sports Stadium. With the use of air structures such permanence is not required and so the additional restrictions of the fixed site should now be avoided. In effect, large air structures can enable planners to reverse the pattern of traditional urban congregation and servicing nodes found in existing towns or cities. In new proposed urban settlements such nodes need no longer be permanent generators of fixed urban patterning.

The use of air structures to provide short-term small and medium sized social facilities enables the siting of short-term mobile housing to be independent of towns offering similar facilities.

Air structures are already used to provide industrial production space particularly where the demand for such space is likely to fluctuate. Thus in effect we already have the mobile factory, but it must be further developed and its potential further exploited.

Work on disaster control and emergency planning has, over the past years, produced a wide range of pneumatic appliances and applications such as *fabridams*, *dracones*, vehicular *hover-pads* and *GEMs* or hovercraft. However, such uses of air structures have not yet been seen as a method of reducing the dependence of emergency planning. That is, they have not been viewed as a potential asset to society enabling rapid yet variable control and communication to be achieved. Such realisation, backed by increasing design and development work, can enable air structures to contribute to a higher degree of sensitivity in society's continuous control of the physical environment.

This conference and the possibilities of future exchange that it has created must assist in establishing new priorities for future work. While I accept the fact that development of present projects is by no means perfect, a desire to achieve greater accuracy in the immediate tasks must not impair our realisation of the future potential.

Pneumatics, as far as partial or total structuring are concerned, are likely to stagnate unless this is realised. The field of valid application has scarcely been touched.

The determination of the extent, interaction and location of activities that require buildings is no longer a sufficient brief.

The quantitative assessment of the valid social life related to particular location must also be made and designed for.

This then is the major role for air structures now and in the future.

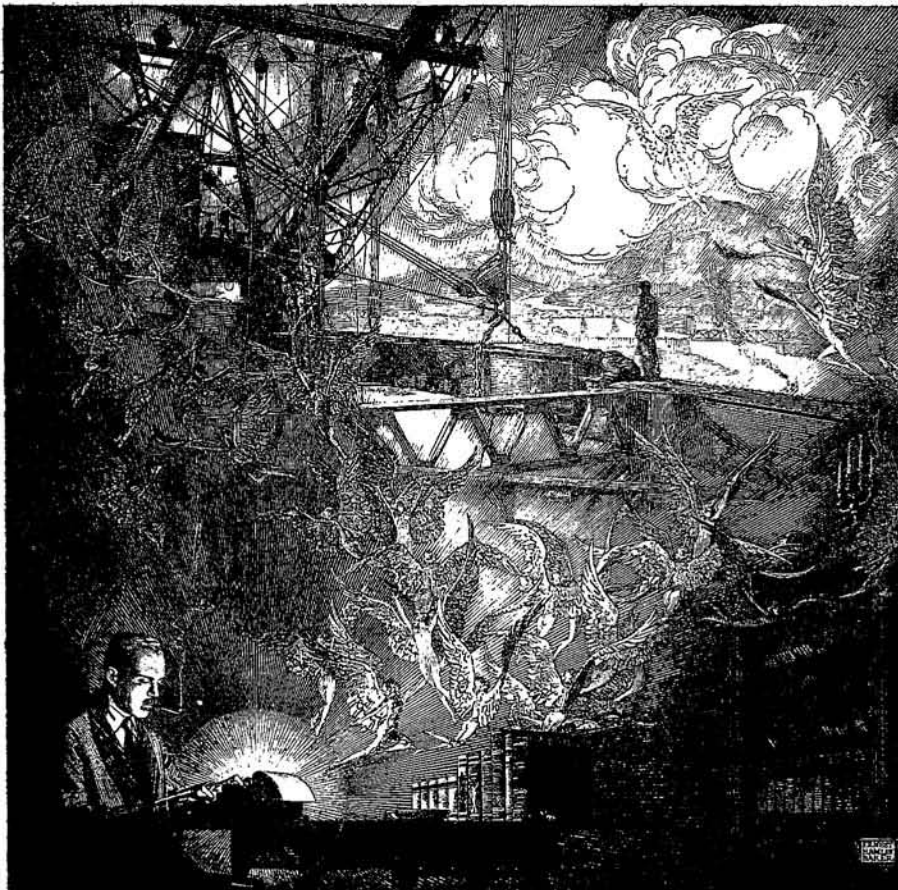

Oakland Tribune

A RESPONSIBLE METROPOLITAN NEWSPAPER

YEAR, NO. 1

G

WEDNESDAY, APRIL 22, 1972

10c DAILY

Faculty Urges U.C. Control of Air Labs

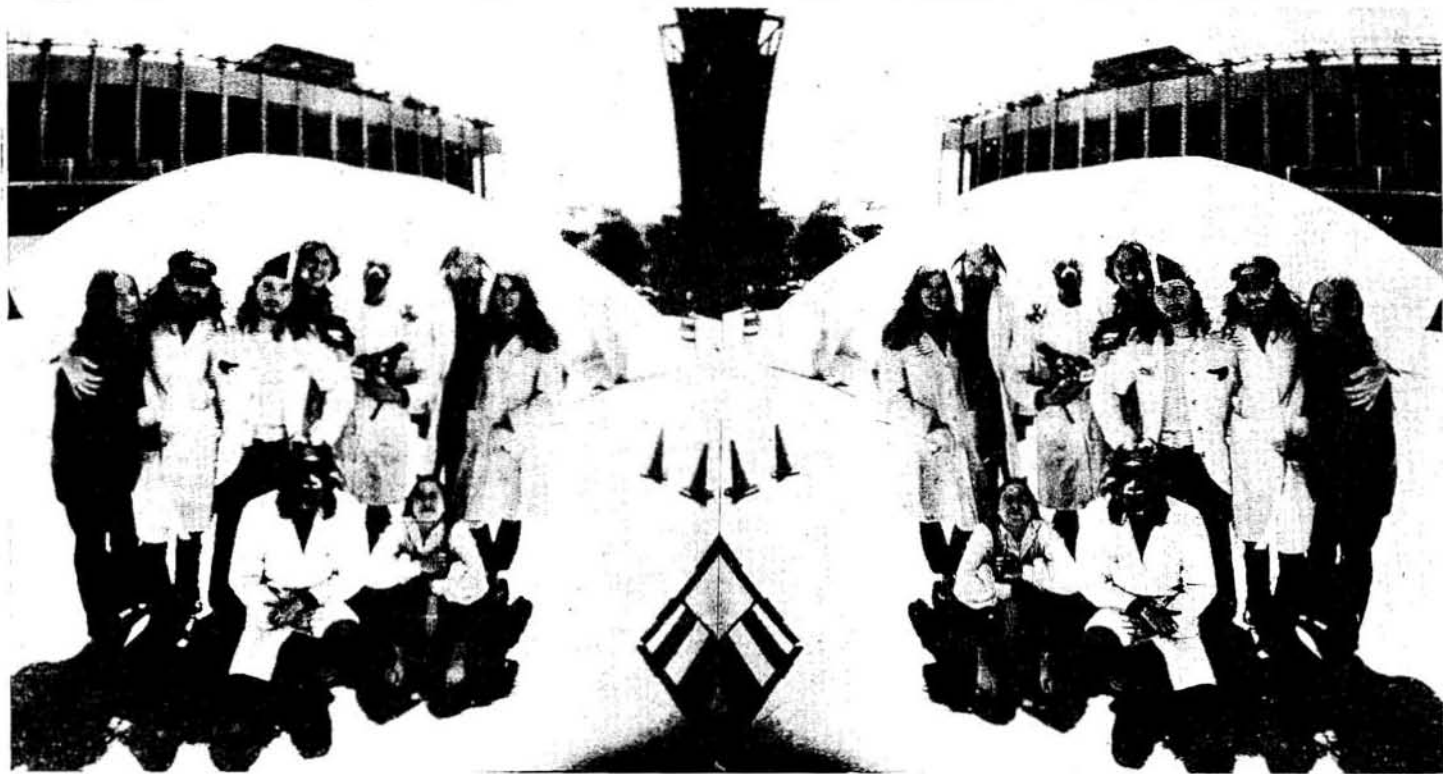

Some dared to enter, others just gaped at this huge plastic air container in lower Sproul Plaza at the U.C. Campus

Tribune photo by F-310.

Breathing— That's Their Bag

BERKELEY—A 40-by-40-foot plastic bag was the theater, stage and prop yesterday for a chillingly realistic bit of theater about a day when the air becomes too polluted to breathe.

"Air Emergency" was conceived and built by a Sausalito "family" of dropout architects called the Ant Farm. The commune, touring Ameri-

can campuses with their Clean Air Pod (CAP 1500) performed outdoors at the University of California campus as part of a three-day Environmental Teach-in.

As an air raid siren drew U.C. students to lower Sproul Plaza, a monotone loudspeaker voice informed them that an "air failure" had occurred and those who couldn't escape from the pollution would die within 15 minutes.

The voice invited onlookers to take shelter in the CAP 1500 which, it said, had been tested "in Akron under government contract." The air system inflating CAP 1500 also screens out deadly pollutants, the voice said.

Those who didn't go into CAP 1500 were given "negative census forms" to fill out before dying.

White-jacketed Ant Farm members wearing gas masks

affixed small yellow circles to onlookers' foreheads. "These are sensors which can be monitored by a Human Resources Satellite which is tracking your final movements," it was amiably explained by a man called "F-310," who described himself as a "human mentad programmed only to answer questions from the press."

The teach-in concludes today.

FANTASY

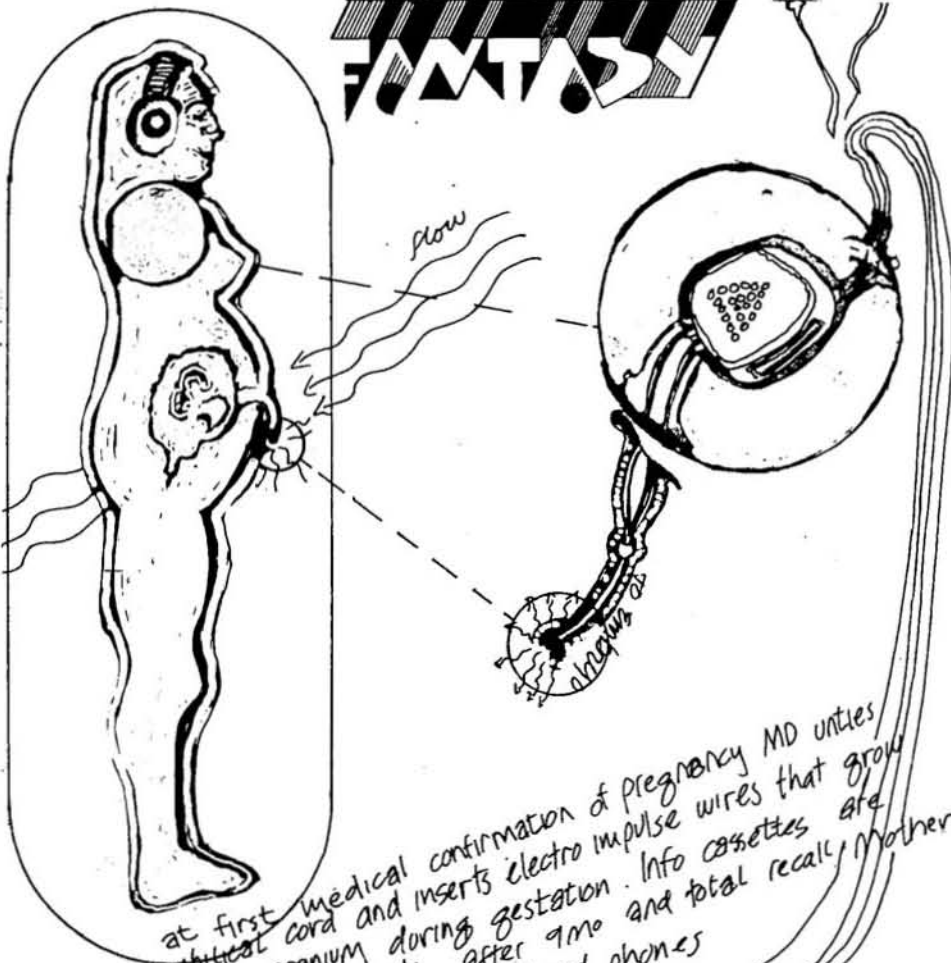

at first mothers womb
 into embryo's cranium
 programmed by parents
 may communicate by head phones

Medical confirmation of pregnancy MD unties cord and inserts electro impulse wires that grow during gestation. Info cassettes are after 9mo and total recall Mother are

GLOBE CITY TODAY was a one night show at the Sausalito Art Center in which we were given total control over the environment, music, admission charge, etc. We inflated a weather balloon dome about 30' dia. in the center, with a long tube entrance and squeeze-through hot lips at either end, plus a small inflatable with a water bed in it, a shrouded picture phone center with the help of The Cinema Workshop video equipment, an inflatable sculpture, and other extras (see Plan). Admission was by barter, or \$1.50 donation - we got 44 dollars, 4 joints, and one Budweiser - not enough to pay expenses, a lot of people got in free. There was a band that never came, but the environment took over and especially the picture phone was a dynamite invisible environment between the inside (of the balloon) and the outside. This event would have been ideal for a sequential time audience like a museum where we could live in it for say a week. It was a tremendous energy output for a one night stand, we forgot to take any photos.

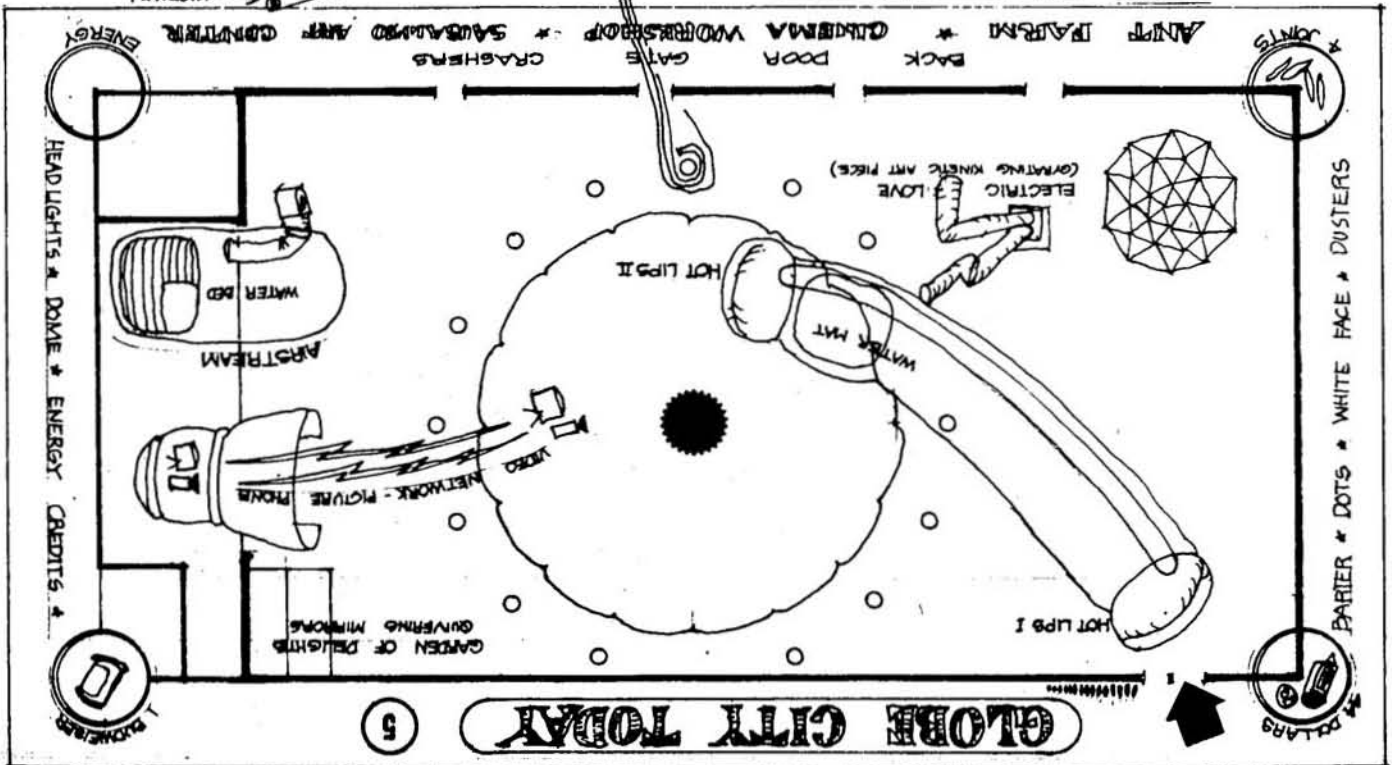

TRUCKIN' UNIVERSITY

EDUCATIONAL DIVISION OF SOUTHCOAST, INC.

A FULLY ACCREDITED LIFESTYLE INSTITUTION



Mr. Goodbar sez:

(HE'S NOT SHITTIN' AROUND)

GET A GOOD

AMERICAN

EDUCATION WHILE YOU STILL GOT A CHANCE!!



-GET SET FOR THE FUTURE!!
-STEP UP TO GOOD FRY!!

NO. INPUT/TOOLS

PROCESS

OUTPUT

27	<p>SCHOOL BUS MODIFIED FOR MOBILE EDUCATIONAL STIMULI AND LIFE SUPPORT VEHICLE FOR THE FACILITATORS/CREW.</p>	<p>SEE CAPABILITY OBJECTIVE AND KEEP READING</p>	
14	<p>STAGE III MEDIA VAN WITH LATEST HIGH OUTPUT ACCESSORIES AND LIFE SUPPORT FACILITIES FOR CREW.</p>	<p>AIN'T YOU NEVER HEARD ABOUT THE SOUTHCOAST MYTH OR HOTFOOT OR ANYTHING? KEEP READING.</p>	
5	<p>PORTABLE VIDEOTAPE CAMERA AND PORTABLE TAPE TRAP UNIT.</p>	<p>SPECIAL EFFECTS DECK FOR EDITING, ALTERING, OR MONITORING VIDEO INPUT. VEHICLE 1.</p>	<p>VIDEO BLOWUP PROJECTOR FOR LARGE SCALE DISPLAYS AND ENVIRONMENTAL SPECIAL EFFECTS.</p>
10	<p>SUPER 8 AND 16 MM FILM CAMERAS FOR RESPONSE DOCUMENTATION.</p>	<p>FACTORY FILM PROCESSING</p> <p>EDITING AND SPLICING FACILITIES. VEHICLE 1.</p>	<p>PROJECTORS AND VARIOUS SURFACES FOR PROJECTION... PLASTIC, PARACHUTES, BUILDINGS</p>
3	<p>35 MM STILL CAMERAS WITH COMPLETE SET OF LENS, FILTERS, AND ACCESSORIES.</p>	<p>FACTORY COLOR FILM PROCESSING</p> <p>MOBILE DARK-ROOM FACILITIES IN VEHICLE 1.</p>	<p>SLIDE PROJECTORS MAY BE MODIFIED FOR HANDHELD PORTABILITY AND MAY BE PROJECTED ON A VARIETY OF SURFACES.</p>
81	<p>LINEAR MEDIA MACHINES SUCH AS TYPEWRITERS AND DRAWING EQUIPMENT PLUS CREDIT CARD FOR LOCAL REPRODUCTION FACILITIES.</p>	<p>ACCUMULATION AND ORGANIZATION OF MATERIAL FOR PRINTING. PUBLICATION PREPARATION FACILITIES TO BE IN VEHICLE 1.</p>	<p>LINEAR MEDIA IS USEFUL AS HISTORICAL TESTIMONY OF A CHANGING REALITY. MAKES GOOD ASS WIPES TOO... TRY THIS ONE.</p>
9	<p>PHONOGRAPH, AM/FM TUNER, TAPE RECORDERS, MICROPHONES, AMPLIFIER OUTPUTS FED INTO CENTRAL AUDIO CONTROL PANEL.</p>	<p>CENTRAL AUDIO CONTROL PANEL SELECTS AND MODULATES OUTPUT FROM VARIOUS INPUTS.</p>	<p>ASSORTMENT OF HIGH PERFORMANCE SPEAKER SYSTEMS FOR USE AS ENVIRONMENTAL MODULATORS.</p>
35	<p>COMMUNICATION BETWEEN INDIVIDUALS IN DISCRETE SPECIALTY FIELDS</p>	<p>ACCESS TO AND USE OF LOCALIZED, NON-MOBILE TECHNOLOGY AND RESOURCES.</p>	<p>PROTOTYPICAL TECHNOLOGICAL AIDS TO ENVIRONMENTAL CONTROL, EDUCATION, CULTURE, ETC.</p>

12

POLYETHYLENE, SILVER MYLAR, POLYTAPE, AND OTHER LARGE AREA FLEXIBLE MEMBRANES.

GROUP ENERGIES INVOLVED IN DESIGN AND EXECUTION OF PNEUMATIC ENVIRONMENTS. DISPOSABLE BUILDING SYSTEMS. CREATES A NEW INVOLVE/EVOLVE PROCESS IN STAGNANT EDUCATIONAL ENVIRONMENTS

76

WOOD DOWELS, ALLOY CONDUIT, PLASTIC CONNECTIONS, RUBBER HOSE, AND OTHER COMMON INEXPENSIVE MATERIALS.

DEMONSTRATION AND EXPLANATION OF ENVIRONMENTAL STRUCTURAL SYSTEMS USING WHOLE EARTH TECHNOLOGY AND WHITE TRASH RESOURCES. GROUP INVOLVEMENT DURING ERECTION STIMULATES NEW APPLICATION OF STRUCTURAL SYSTEMS.

6

COMBINATION OF THE ABOVE TOOLS INTO A MOBILE THOUGHT PROCESS STIMULATION SYSTEM RELEVANT TO A SPACE AGE CULTURE.

CREATION OF ENVIRONMENTAL SENSORY OVERLOAD CONDITION WHEN PERSONAL INPUT SYSTEMS OVERLOAD PROCESSING SYSTEM (BRAIN) AND INADEQUACY OF CURRENT EDUCATIONAL/PROGRAMMING SYSTEM IS SHOWN. SEE ALSO: FREAKOUT, MIND FUCK, COSMIC TRUTH, ETC.

47

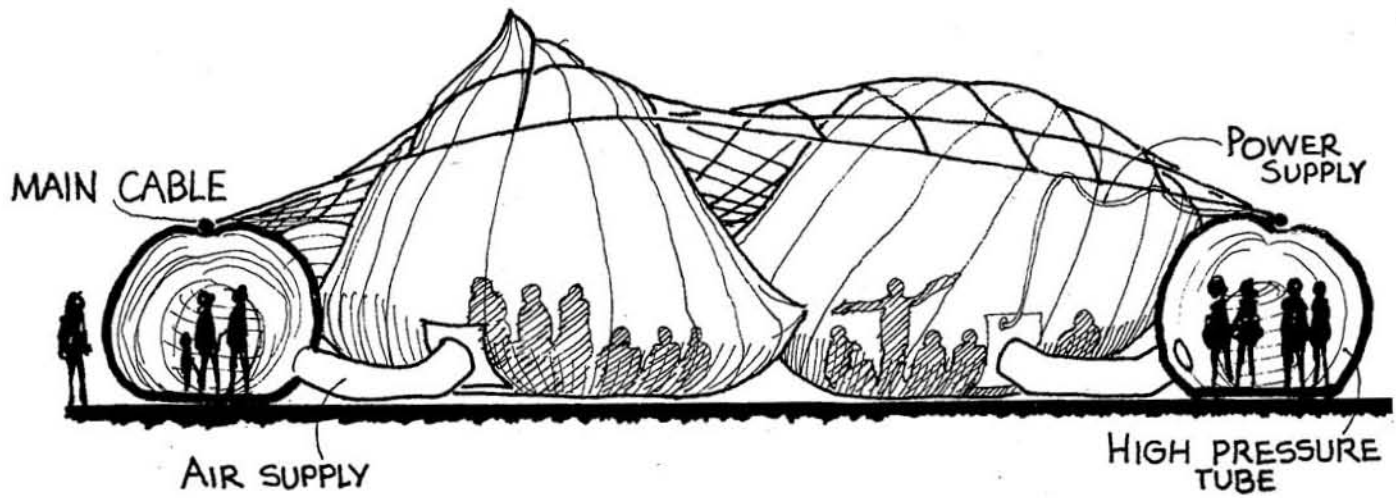
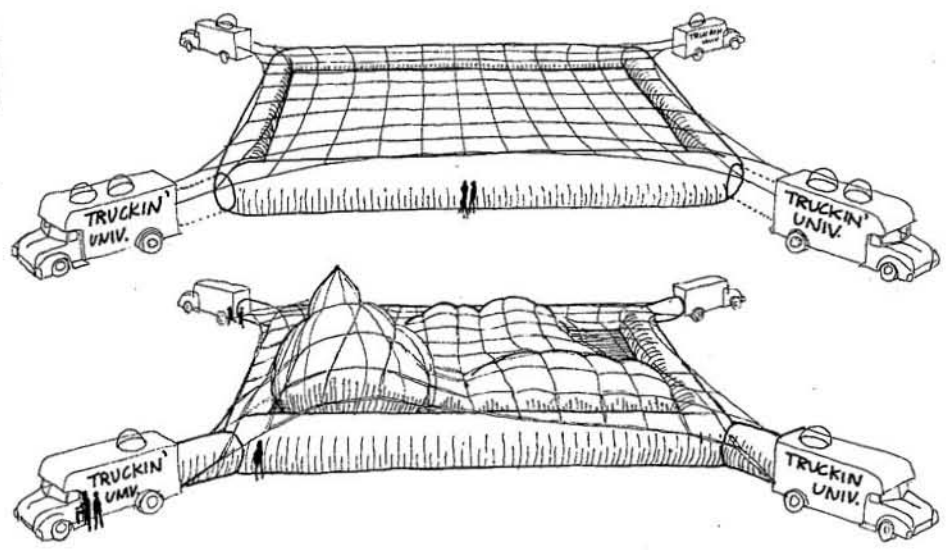

Instant Site capability, the whole packing down, into four trucks. The tube provides air and access; the net, when spread & tightened serves to windproof many light weight inflatables, being built and changed according to the activities within. The main cable also provides electricity.

HY-TEK

December 2, 1970

Still seeking/searching for ways to increase the network. We have to stop trucking, stay home a few months to produce the Inflatocookbook, to study the mobile lifestyle, got some money to advance the art, keep everybody comfortable, rest up, that's why we need the TRUCK STOP. Institutions in the dominant culture burden our mobility/growth, yet what we are talking about is an institution, a communication network of places like ours, where media nomads can pull in off the road (earn College Credit!), repair a truck, sometimes it is a City *Real(C)ity* all spread out across the country (for now) with mobile hardware connecting, three weeks in freedom city, two weeks in the mountain, moving on and making Real connections with a real culture. Sometimes it is a school, incidental education for wandering learners (all ages) a really valid system that supplies resources and a multitude of opportunities to expand. Sometimes it is our warehouse providing bare minimum needs of space to work (vinyl welder, library, office, drafting boards, kitchen, video studio, darkroom, sewing corner, office, drafting boards, kitchen, media studio) overworked with high energy information Xchange, people dropping in to ask (call first) or just hanging out trying to find space to be alone.

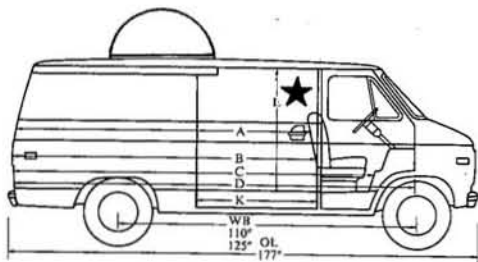

nomad section:

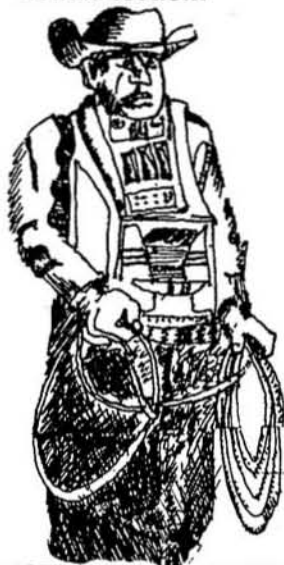

8 7 6 5 4 3 2 1
 4 6 7
 7 6 5 4
 1 2 3 4
 8 7 6 5
 1 2 3 4
 4 3 2
 8 7 9
 4 3 2
 7 6 2
 8 7 9
 4 3 2
 1 2 3 4

The nomad is a peculiar animal. He (big'nburlywithhairgrowin'outallover) travels either in a tribe (the thunder ofathousandburninghoofs) or alone in a never-ending search for nutrients. Were he to remain in one place he would surely perish because (whydon'tyoufindaniceplaceandsettledown) although that place doubtless contributes one nutrient to his system (heressomeland-andmydaughtershand) it can't supply other needs necessary for survival, thus he seeks out multidimensional inputs from many environments (wellhad-newsfromthefrontiers). Today it may appear that there is a sampling of many enviroons in a given region, the media (Goodnightdavid) is only similar with varying content (allHowardJohnsonsarethesameexceptfortheactors). Now nutrients are in the form of high energy inputs shot to the psyche thru the senses from those who "speak your language" (approachEdgeCitywiedtrip-actions naturally emitted or communicate in some other manner, such as (goodvibes) or the present value judgments as expressed in outward visual appearance (likelwalkinandldon'thavetohasslewithihowareyoushit,wejuststart to communicate similar viewpoints at a given time and place in the evolution of youth of today is not so much a playful tendency as a true need for honest nutrient input vital to the survival of man today. Nomads (Indian/Gypsy/hobo/hun) travel to provide nutrients (grass/water/winds/food/riches) necessary for their survival. The culture now induces maxi-viewing, uoqewajoyu! Adjaua ubiy Xchange, not found at Beechwood High School. Super kid of today finds no maxi-nutrients in existing props, so he hits the road. He takes what he needs from different places, producing only one thing: HIMSELF, a system resource center for creating tools to solve any problem. Where he is going is where he is at. (goodnightChet)



... written by TL, on his way to Globe City



GOOD TASTE PAGE
SOBWAEND

FANTASY

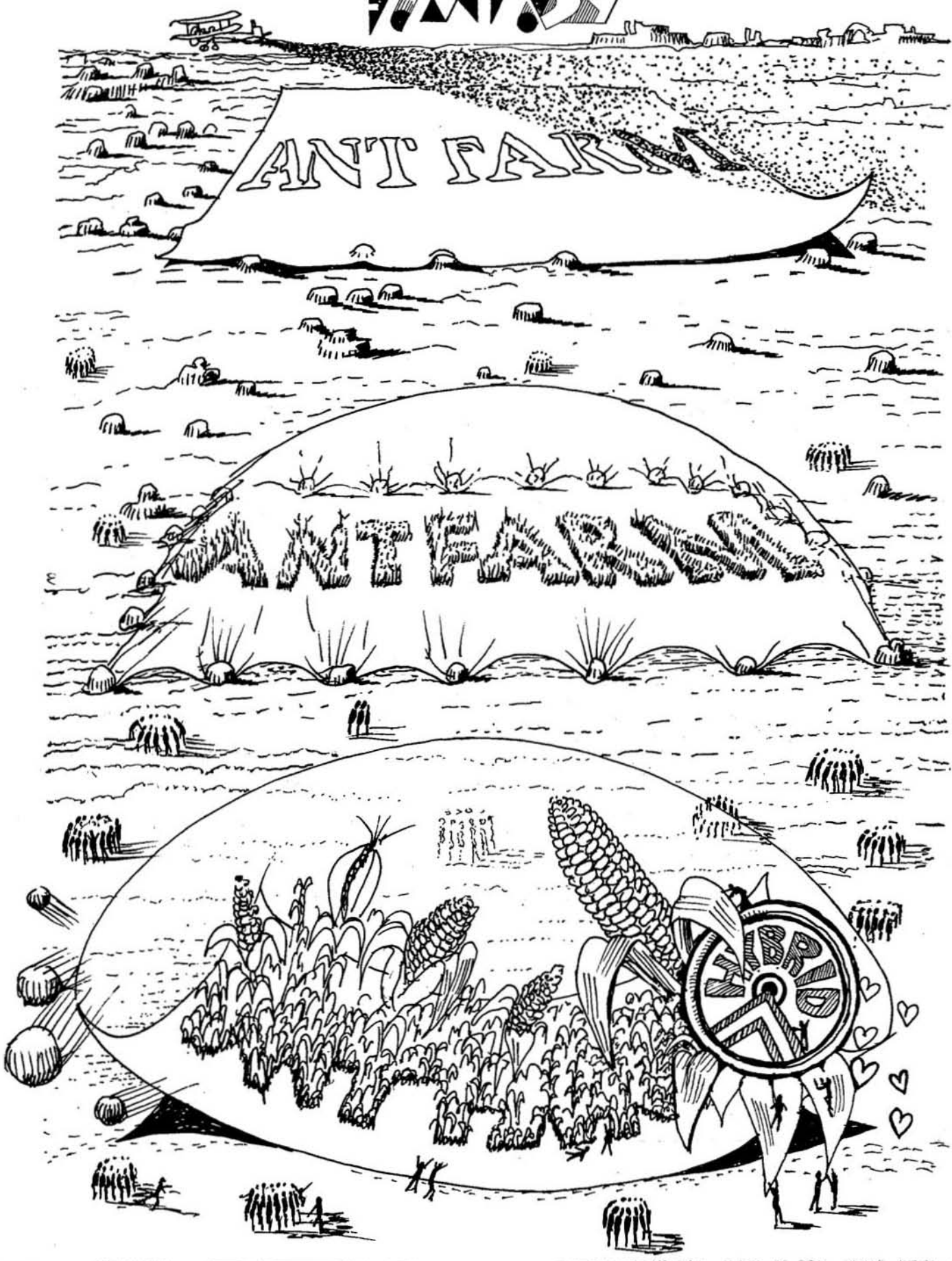

FANTASY 10 9 8 7 6 5 4 3 2 1

PNEUMATICS 4 3 2 1

EVENTS 1 2 3

1

Reasonable Facsimile Earth Wks.
John Paskiewicz
17 Welsford
Pittsburgh Pa 15213

Erwin S Strauss
TTA Enterprises
1015 Laguna St suite 10
Santa-Barbers Ca. 93101

Bob Colomb
POBox 8103
Kansas City Mo. 04112

Bud Donnelly
POBox 2181
Cincinnati Ohio 45202

Look at basketballs, volleyballs
clothing design
Mathematical Models
H. Martin Cundy
1960! 280pp.
\$6.50

THE INFLATONETWORK
(as we know it)

Charley Tilford
%Antioch
Columbia Md.

Chrysalis/Paris
7 Rue Des Ecuyers
7800 St.Germain En Laye
France

Hugh McCarney
20 William St
Mt Vernon N.Y. 10552

Alley Friends
3300 Rage St
Philadelphia Pa 19104

Jay Steinhauer
1125 Cleveland
La Grange Pk Ill 60525

BUBBLE PRIMER-philosophy
for an inflatable college and
a kind of feasibility report
from: Ruruk Ekstrom AIA
10351 Barcan Circle
Columbia MD.

the Hindenberg
echo 1
inner tubes
balloon clubs
parachutes
air mattress & boats
soap bubbles
22.50\$
1660 illustrations
1967,320 pp.
Frei Otto
Pneumatic Structures
Tensile Structures Volume One

W.M. Grainger Inc. Catalog
5959 Howard St
Chicago Ill 60648
312 775 4400

Plastics-Fabrics, Film & Sheets
H. T. McGill
P.O. Box 517
4511 Front St.
Brookshire, Texas 77423
GROSS PLASTIC FILM CORP
IMPORTERS - DISTRIBUTORS
MITSUI & CO.
WAREHOUSED IN LOS ANGELES
VINYL FILM & SHEETING
INDUSTRIAL TAPES
SLITTING FACILITIES
OUR TRUCKS DELIVER IN AREA
3610 S Broadway.....231-1131
HARTFORD TEXTILE CORP
Producers of Beaufilm & Beutalon
Printed & Embossed Vinyls
Polyethylene, Film & Sheeting
3301 S Main.....749-2731

from LA. phone book

Architectural Design
The only periodical to consistently
publish state of the art material on
pneumatic structures.
13.50\$ per year
Architectural Design
26 Bloomsbury Way
London W.C. 1 England
June 1966 issue has a complete
issue on pneumatic structures.

ARCHIGRAM MAGAZINE IS
PUBLISHED FROM
59 ABERDARE GARDENS
LONDON N W 6

Birdair Structures, Inc.
2015 Walden Ave.
Buffalo, New York 14225

Raven Industries, Inc.
P.O. Box 916
Sioux Falls, S.D. 57101

Air-O-Structures
a division of Lewiston-Auburn Awning Co.
P.O. Box 296
Auburn, Maine

Industrial Covers
2045 Evans Ave.
San Francisco, Calif. 94124

A.B. Chance Co.
Jersey Ave
New Brunswick N.J.

TAPE

4 3 2 1 MATERIALS

GEOMETRY 8 7 6 5 4 3 2 1

4 3 2 1 ANCHORING

FUNDAMENTALS

AIR SUPPLY 1 2 3 4 5 6



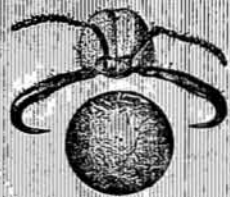

מ.ה.מ.ז.א.מ.